

Features

- Center amplifying gate
- Metal case with ceramic insulator
- Low on-state and switching losses

Typical Applications

- AC controllers
- DC and AC motor control
- Controlled rectifiers

$I_{T(AV)}$ 830 A
 V_{DRM}/V_{RRM} 5600-6500V
 I_{TSM} 11.8 kA
 I^2t 696 $10^3 A^2S$

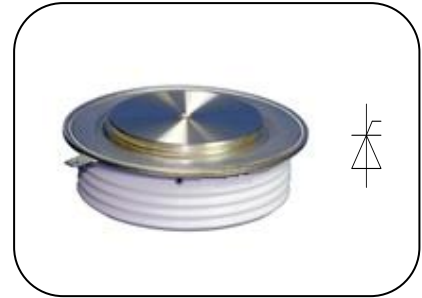

SYMBOL	CHARACTERISTIC	TEST CONDITIONS	$T_j(^{\circ}C)$	VALUE			UNIT
				Min	Type	Max	
$I_{T(AV)}$	Mean on-state current	180° half sine wave 50Hz Double side cooled, $T_C=70^{\circ}C$	125			830	A
V_{DRM} V_{RRM}	Repetitive peak off-state voltage Repetitive peak reverse voltage	$t_p=10ms$	125	5600		6500	V
I_{DRM} I_{RRM}	Repetitive peak current	at V_{DRM} at V_{RRM}	125			200	mA
I_{TSM}	Surge on-state current	10ms half sine wave	125			11.8	kA
I^2t	I^2t for fusing coordination	$V_R=0.6V_{RRM}$				696	$A^2s \cdot 10^3$
V_{TO}	Threshold voltage		125			1.25	V
r_T	On-state slope resistance					1.03	m Ω
V_{TM}	Peak on-state voltage	$I_{TM}=1000A, F=24kN$	125			2.40	V
dv/dt	Critical rate of rise of off-state voltage	$V_{DM}=0.67V_{DRM}$	125			2000	V/ μs
di/dt	Critical rate of rise of on-state current	$V_{DM}= 67\%V_{DRM}$ to 2000A, Gate pulse $t_r \leq 0.5\mu s$ $I_{GM}=2.0A$	125			100	A/ μs
Q_{rr}	Recovery charge	$I_{TM}=2000A, t_p=2000\mu s, di/dt=-5A/\mu s,$ $V_R=50V$	125		2500		μC
I_{GT}	Gate trigger current	$V_A=12V, I_A=1A$	25	40		300	mA
V_{GT}	Gate trigger voltage			0.8		3.0	V
I_H	Holding current			25		200	mA
V_{GD}	Non-trigger gate voltage	$V_{DM}=0.67V_{DRM}$	125	0.3			V
$R_{th(j-c)}$	Thermal resistance Junction to case	DC: double side cooled Clamping force 24.0kN				0.020	$^{\circ}C/W$
$R_{th(c-h)}$	Thermal resistance case to heatsink					0.005	$^{\circ}C/W$
F_m	Mounting force			19	24	26	kN
T_{stg}	Stored temperature			-40		140	$^{\circ}C$
W_t	Weight				440		g
Outline	P11						

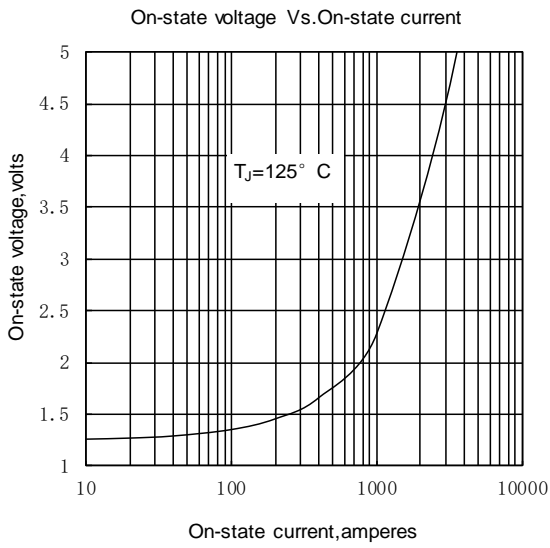

Fig.1

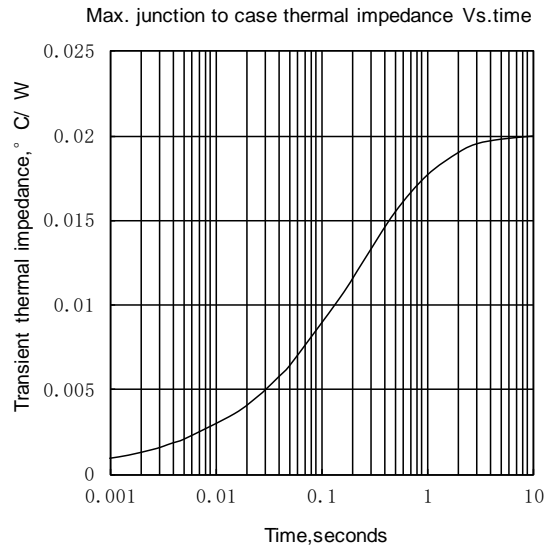

Fig.2

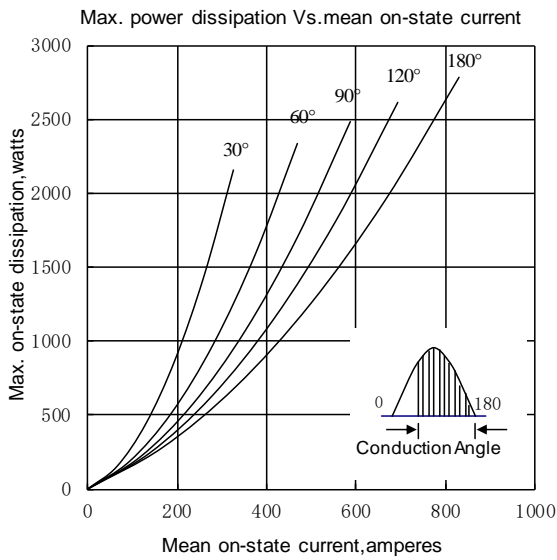

Fig.3

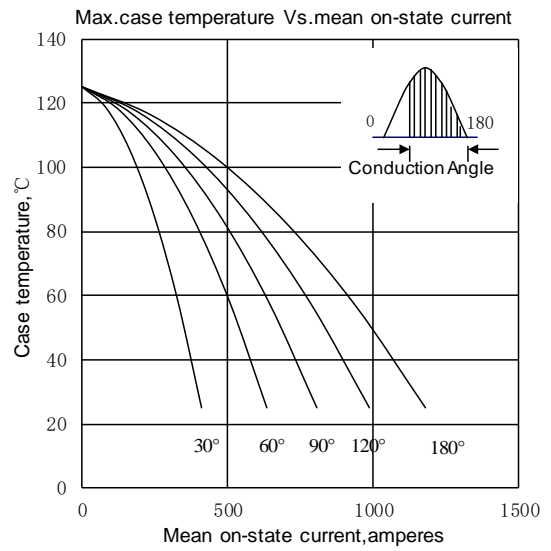

Fig.4

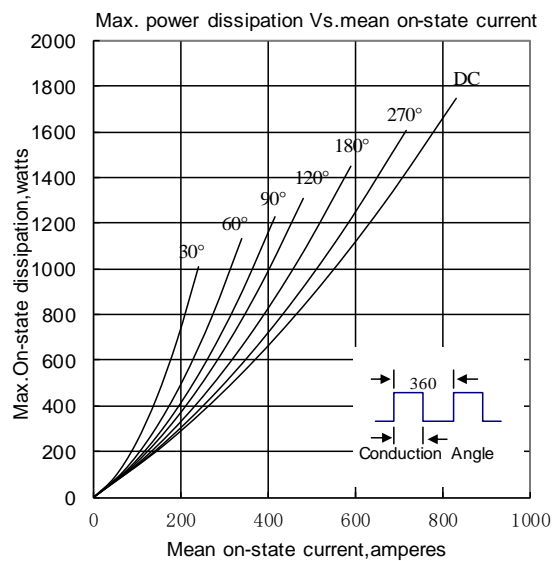

Fig5

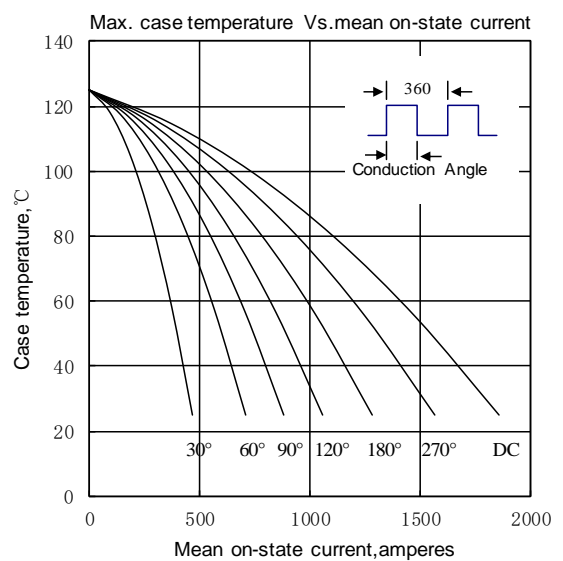

Fig6

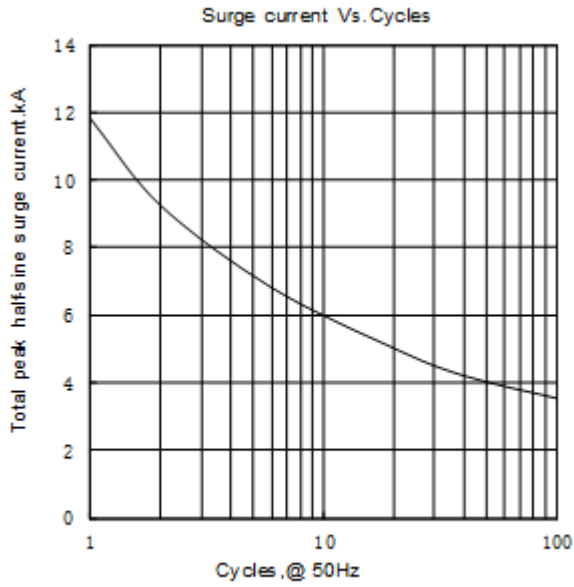

Fig. 7

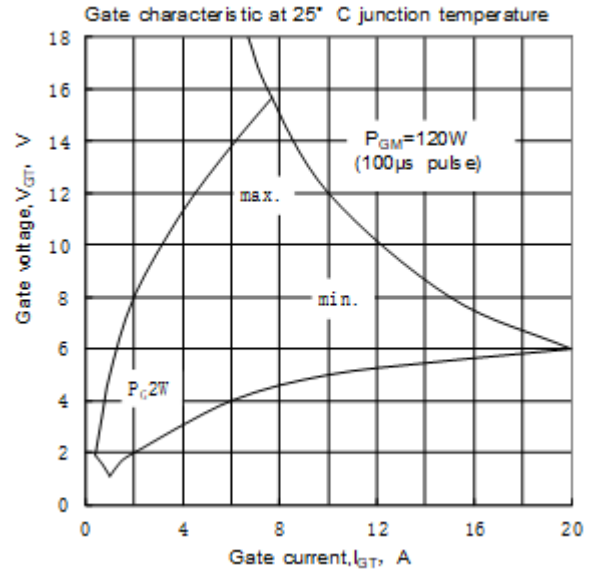

Fig. 8

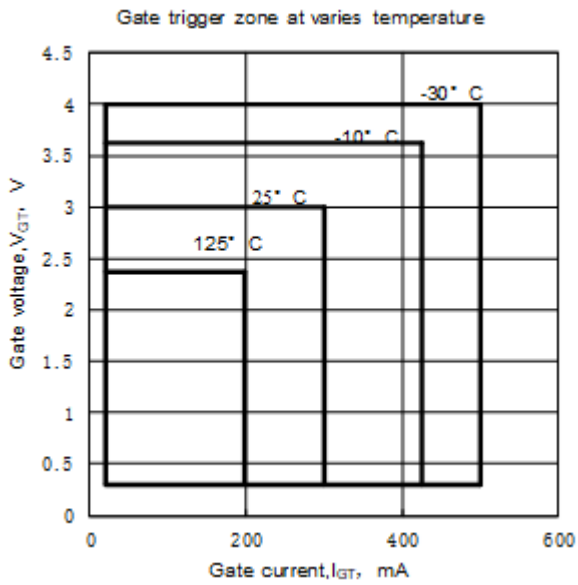
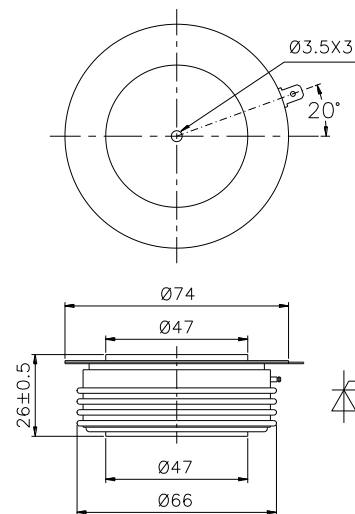

Fig. 9



Nlps reserves the right to change specifications without notice.