

Features

- Interdigitated amplifying gates
- Fast turn-on and high di/dt
- Low switching losses

$I_{T(AV)}$	820A
V_{DRM}/V_{RRM}	800 ~ 1800V
t_q	18~50μs
I_{TSM}	9.0 kA
I^2t	405 10³A²s

Typical Applications

- Inductive heating
- Electronic welders
- Self-commutated inverters

SYMBOL	CHARACTERISTIC	TEST CONDITIONS		T _J (°C)	VALUE			UNIT
					Min	Type	Max	
$I_{T(AV)}$	Mean on-state current	180° half sine wave 50Hz Double side cooled,	T _C =55°C	125			820	A
V_{DRM} V_{RRM}	Repetitive peak off-state voltage Repetitive peak reverse voltage	tp=10ms		125	800		1800	V
I_{DRM} I_{RRM}	Repetitive peak current	at V_{DRM} at V_{RRM}		125			40	mA
I_{TSM}	Surge on-state current	10ms half sine wave		125			9.0	kA
I^2t	I ² t for fusing coordination	$V_R=0.6V_{RRM}$					405	A ² s*10 ³
V_{TO}	Threshold voltage			125			1.36	V
r_T	On-state slope resistance						0.53	mΩ
V_{TM}	Peak on-state voltage	$I_{TM}=1500A, F=15kN$		25			3.15	V
dv/dt	Critical rate of rise of off-state voltage	$V_{DM}=0.67V_{DRM}$		125			1000	V/ μ s
di/dt	Critical rate of rise of on-state current	$V_{DM}=67\%V_{DRM}$ to 1000A, Gate pulse $t_r \leq 0.5\mu s$ $I_{GM}=1.5A$ Single pulse		125			1200	A/ μ s
Q _{tr}	Recovery charge	$I_{TM}=1000A, tp=4000\mu s,$ $di/dt=-20A/\mu s, V_R=100V$		125		460		μC
t _q	Circuit commutated turn-off time	$I_{TM}=1000A, tp=4000\mu s, V_R=100V$ $dv/dt=30V/\mu s, di/dt=-20A/\mu s$		125	18		50	μs
I_{GT}	Gate trigger current	$V_A=12V, I_A=1A$		25	40		250	mA
V_{GT}	Gate trigger voltage				0.9		2.5	V
I_H	Holding current				20		400	mA
I_L	Latching current						500	mA
V_{GD}	Non-trigger gate voltage				$V_{DM}=67\%V_{DRM}$		125	
$R_{th(j-c)}$	Thermal resistance Junction to case	D.C. double side cooled Clamping force 15kN					0.035	°C /W
$R_{th(c-h)}$	Thermal resistance case to heat sink						0.008	
F _m	Mounting force				10		20	kN
T _{vj}	Junction temperature				-40		125	°C
T _{stg}	Stored temperature				-40		140	°C
W _t	Weight					250		g
Outline	P08							

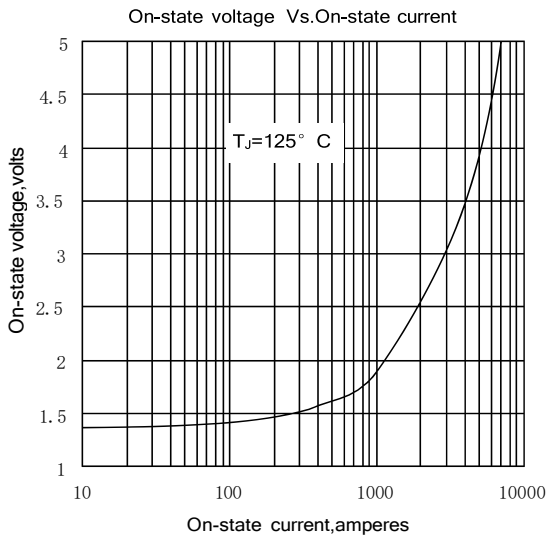

Fig. 1

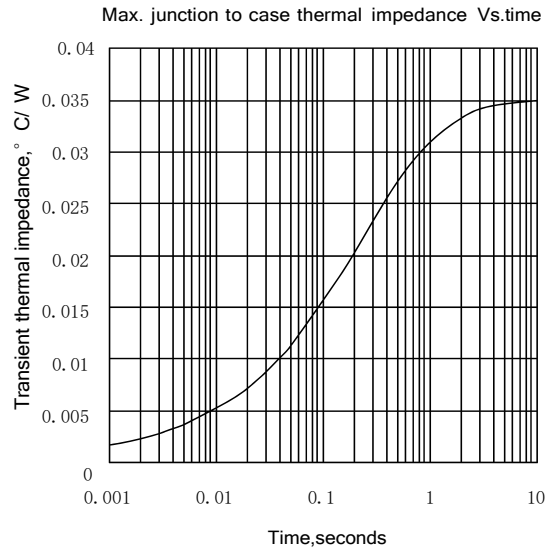

Fig. 2

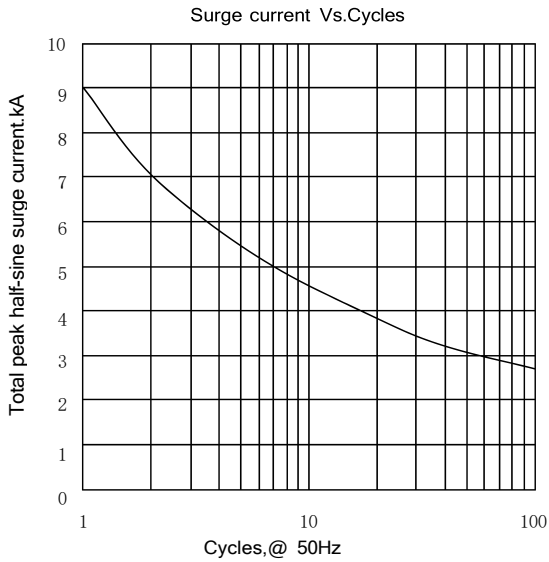

Fig. 3

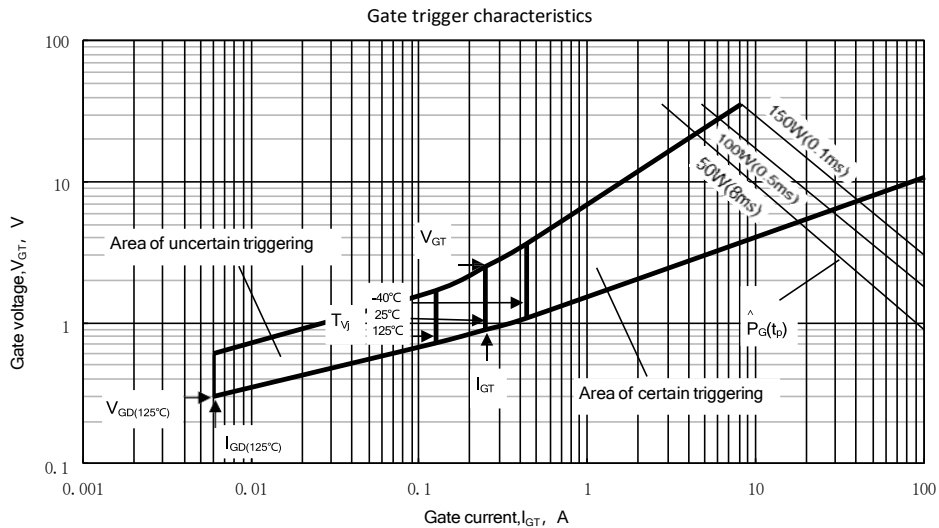
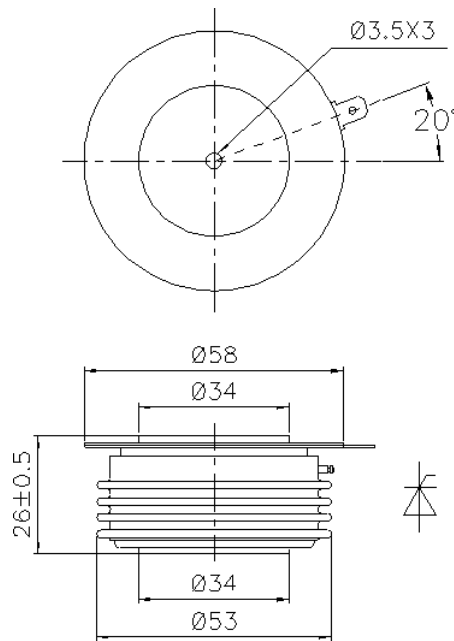

Fig. 4

Outline:



Nlps reserves the right to change specifications without notice.