

Features

- Center amplifying gate
- Metal case with ceramic insulator
- Low on-state and switching losses

$I_{T(AV)}$ **6400A**
 V_{DRM}/V_{RRM} **400 ~ 1200V**
 I_{TSM} **74 kA**
 I^2t **27380 10³A²S**

Typical Applications

- AC controllers
- DC and AC motor control
- Controlled rectifiers

SYMBOL	CHARACTERISTIC	TEST CONDITIONS	T _j (°C)	VALUE			UNIT
				Min	Type	Max	
I _{T(AV)}	Mean on-state current	180° half sine wave 50Hz Double side cooled,	T _C =70°C	125		6400	A
			T _C =55°C	125		7300	A
V _{DRM} V _{RRM}	Repetitive peak off-state voltage Repetitive peak reverse voltage	tp=10ms	125	400		1200	V
I _{DRM} I _{RRM}	Repetitive peak current	at V _{DRM} at V _{RRM}	125			300	mA
I _{TSM}	Surge on-state current	10ms half sine wave V _R =0.6V _{RRM}	125			74	kA
I ² t	I ² t for fusing coordination					27380	A ² s*10 ³
V _{TO}	Threshold voltage		125			0.850	V
r _T	On-state slope resistance					0.055	mΩ
V _{TM}	Peak on-state voltage	I _{TM} =5000A, F=90kN	25			2.00	V
dv/dt	Critical rate of rise of off-state voltage	V _{DM} =0.67V _{DRM}	125			1000	V/μs
di/dt	Critical rate of rise of on-state current	V _{DM} = 67%V _{DRM} to 4000A, Gate pulse t _r ≤ 0.5μs I _{GM} =1.5A	125			250	A/μs
Q _{rr}	Recovery charge	I _{TM} =2000A, tp=4000μs, di/dt=-20A/μs, V _R =100V	125		3500		μC
I _{GT}	Gate trigger current	V _A =12V, I _A =1A	25	50		250	mA
V _{GT}	Gate trigger voltage			0.8		2.5	V
I _H	Holding current			20		1000	mA
I _L	Latching current					1000	mA
V _{GD}	Non-trigger gate voltage	V _{DM} =67%V _{DRM}	125			0.3	V
R _{th(j-c)}	Thermal resistance Junction to case	D.C. double side cooled Clamping force 90kN				0.0050	°C/W
R _{th(c-h)}	Thermal resistance case to heatsink					0.0015	
F _m	Mounting force			81		108	kN
T _{vj}	Junction temperature			-40		125	°C
T _{stg}	Stored temperature			-40		140	°C
W _t	Weight				2000		g
Outline	P21						

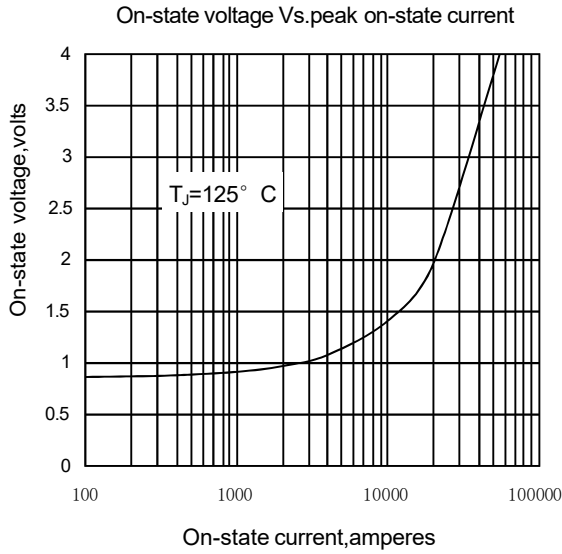

Fig1

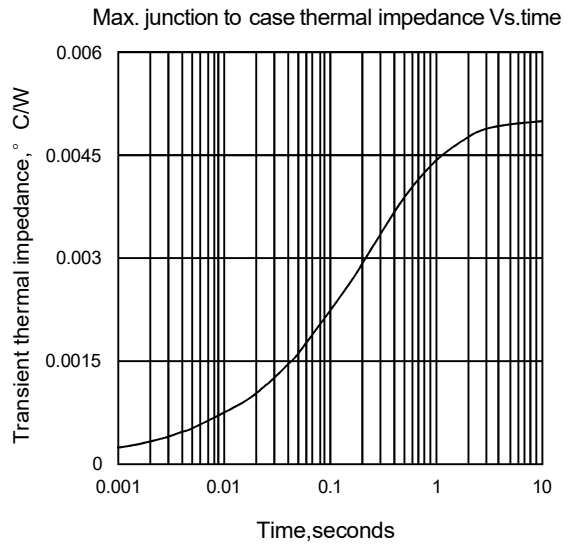

Fig2

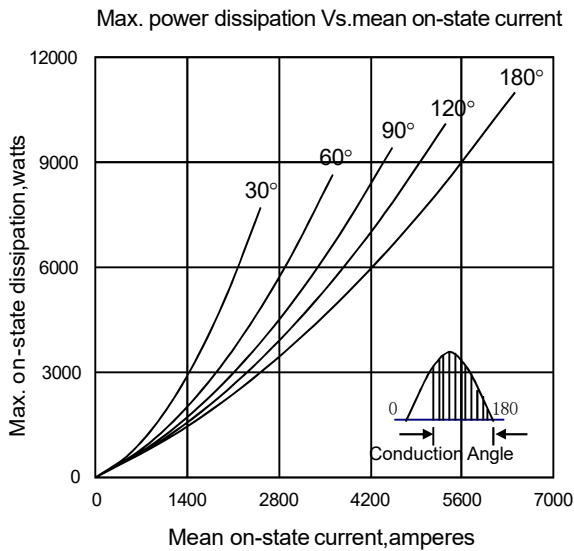

Fig3

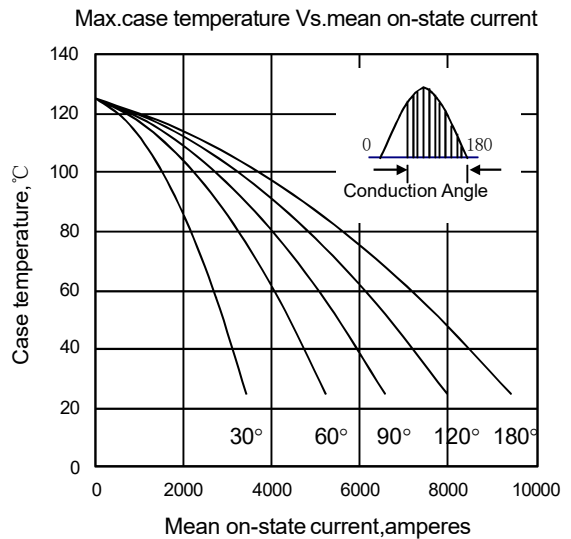

Fig4

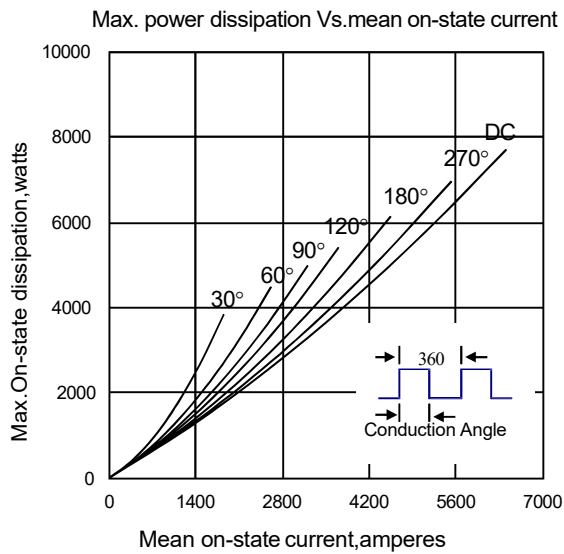

Fig5

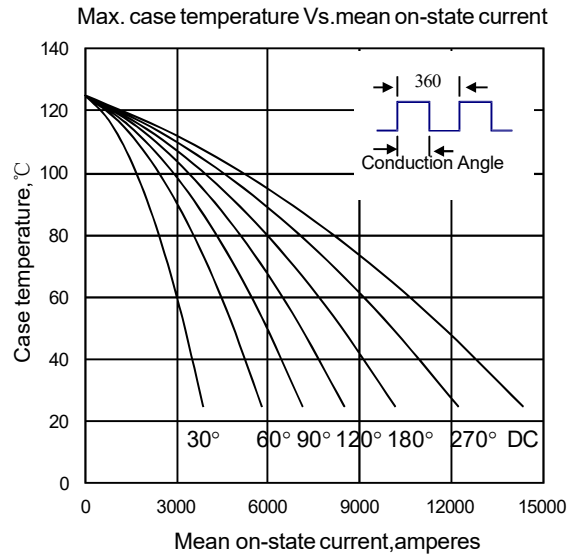

Fig6

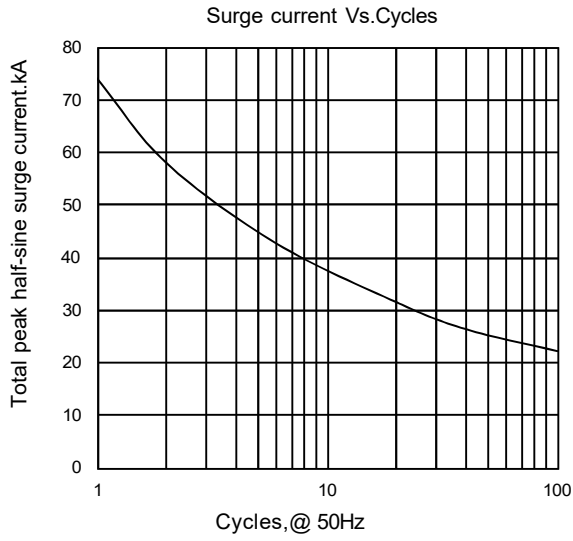

Fig7

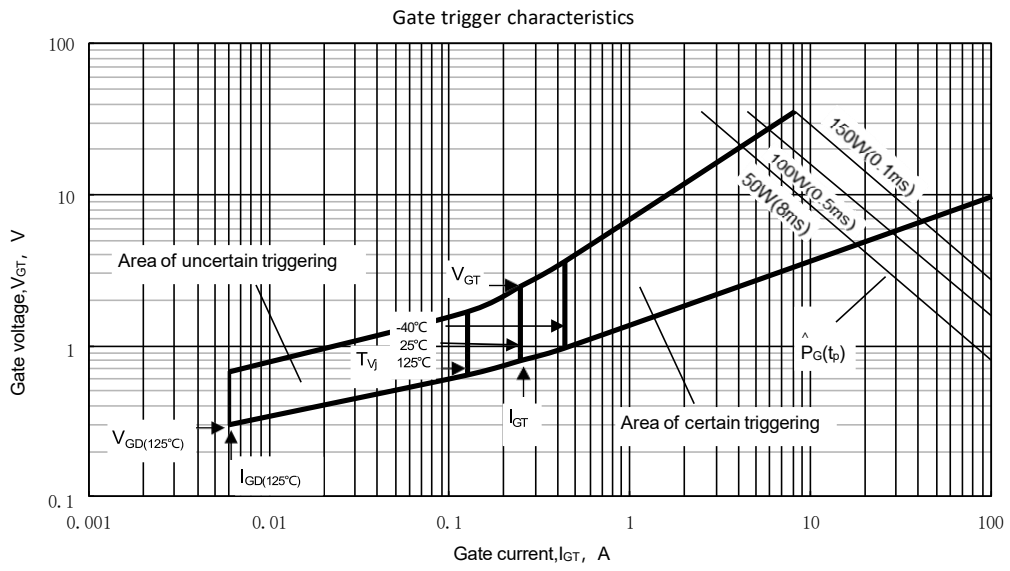
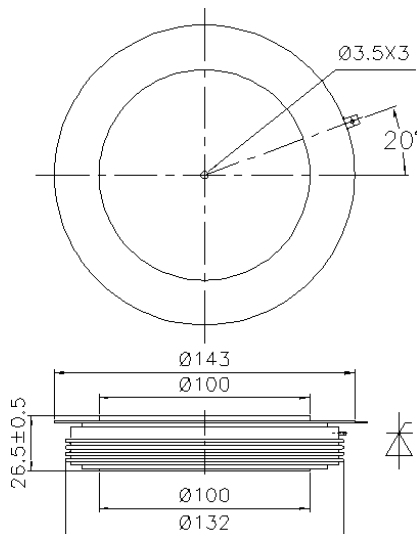

Fig. 8

Outline:



Nlps reserves the right to change specifications without notice.