

Features :

- Center amplifying gate
- Metal case with ceramic insulator
- Low on-state and switching losses

Typical Applications :

- AC controllers
- DC and AC motor control
- Controlled rectifiers

$I_{T(AV)}$ **520A**
 V_{DRM}/V_{RRM} **3600 ~ 4500V**
 I_{TSM} **6 kA**
 I^2t **180 10³A²S**

SYMBOL	CHARACTERISTIC	TEST CONDITIONS		T _J (°C)	VALUE			UNIT
					Min	Type	Max	
I _{T(AV)}	Mean on-state current	180° half sine wave 50Hz Double side cooled	T _C =70°C	125			520	A
V _{DRM} V _{RRM}	Repetitive peak off-state voltage Repetitive peak reverse voltage	t _p =10ms		125	3600		4500	V
I _{DRM} I _{RRM}	Repetitive peak current	at V _{DRM} at V _{RRM}		125			100	mA
I _{TSM}	Surge on-state current	10ms half sine wave		125			6	kA
I ² t	I ² t for fusing coordination	V _R =0.6V _{RRM}						180
V _{TO}	Threshold voltage			125			1.10	V
r _T	On-state slope resistance							1.30
V _{TM}	Peak on-state voltage	I _{TM} =1000A, F=15kN		25			2.40	V
dv/dt	Critical rate of rise of off-state voltage	V _{DM} =0.67V _{DRM}		125			1000	V/μs
di/dt	Critical rate of rise of on-state current	V _{DM} =67%V _{DRM} , Gate pulse t _r ≤ 0.5μs I _{GM} =1.5A		125			100	A/μs
Q _{rr}	Recovery charge	I _{TM} =1000A, t _p =4000μs, di/dt=-5A/μs, V _R =100V		125		1800		μC
I _{GT}	Gate trigger current	V _A =12V, I _A =1A		25	40		300	mA
V _{GT}	Gate trigger voltage				0.8		3.0	V
I _H	Holding current				25		200	mA
I _L	Latching current						1500	mA
V _{GD}	Non-trigger gate voltage	V _{DM} =67%V _{DRM}		125			0.3	V
R _{th(j-c)}	Thermal resistance Junction to case	D.C. Double side cooled					0.035	°C/W
R _{th(c-h)}	Thermal resistance case to heatsink	Clamping force 15kN					0.008	
F _m	Mounting force				10		20	kN
T _{vj}	Junction temperature				-40		125	°C
T _{stg}	Stored temperature				-40		140	°C
W _t	Weight					240		g
Outline	P08a							

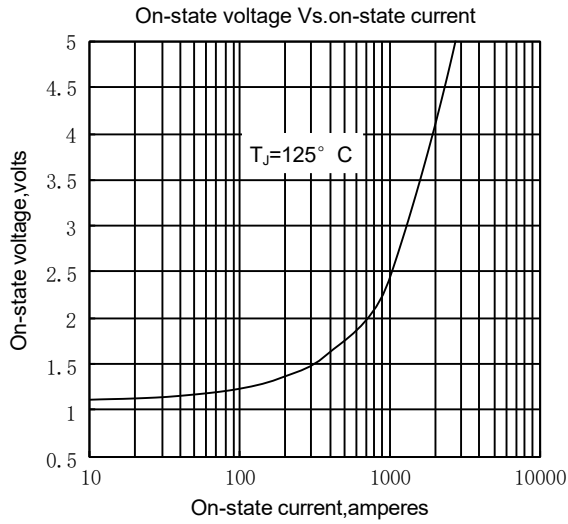

Fig.1

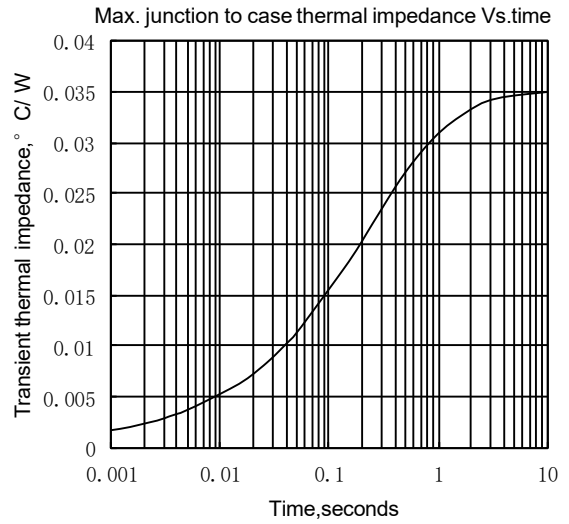

Fig.2

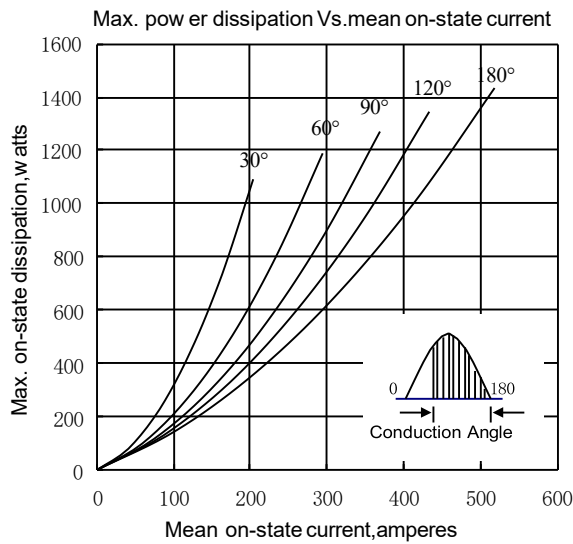

Fig.3

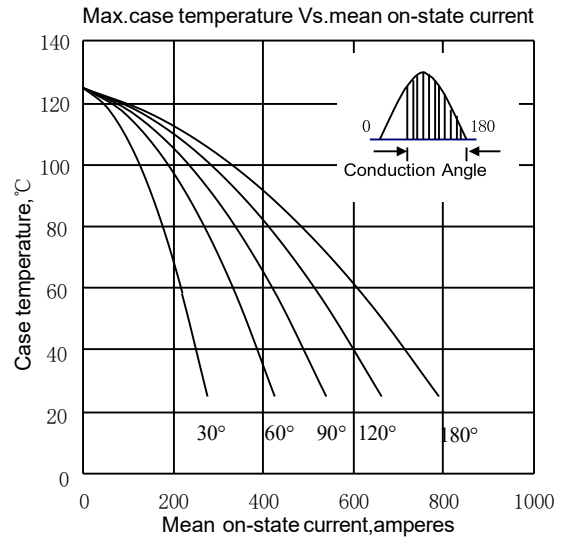

Fig.4

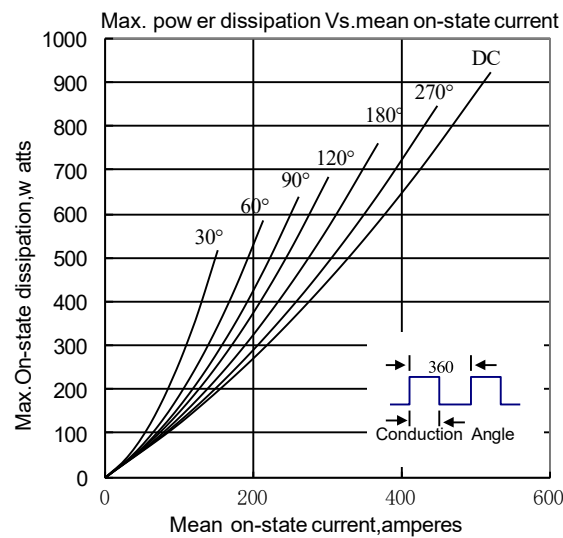

Fig.5

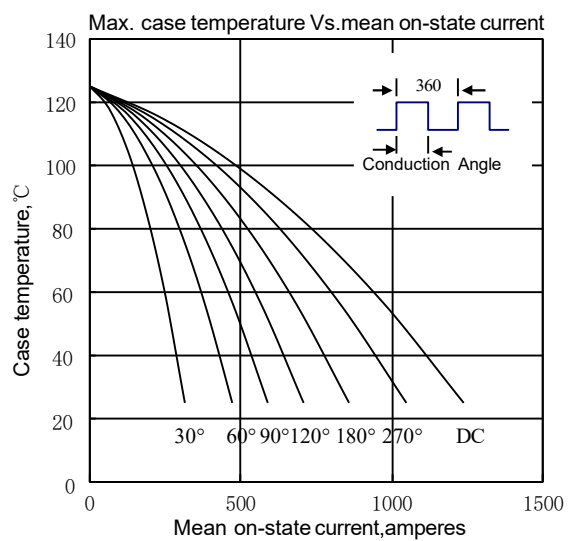

Fig.6

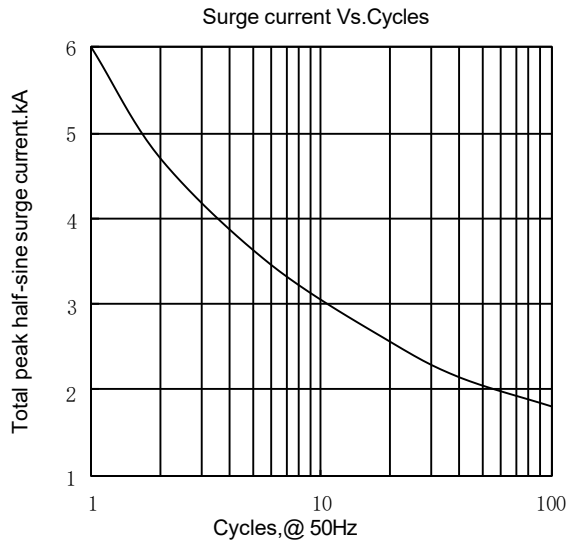

Fig.7

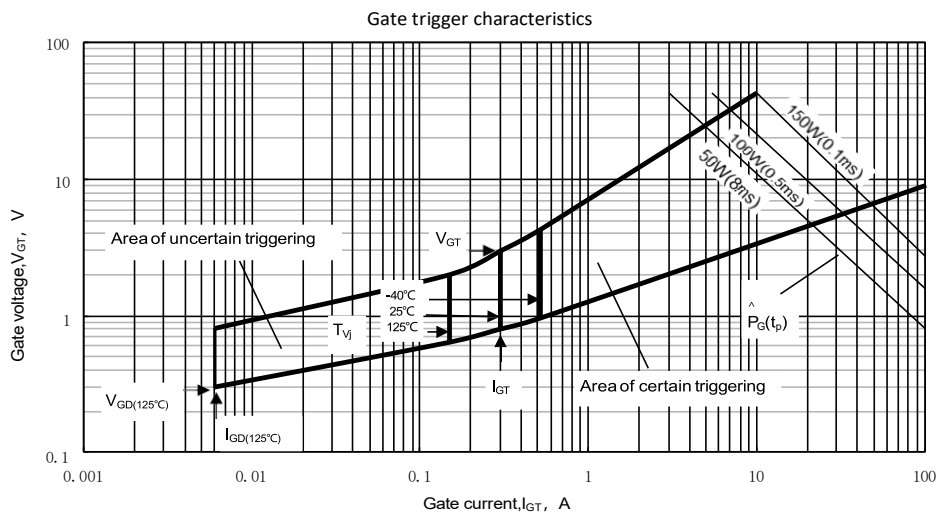
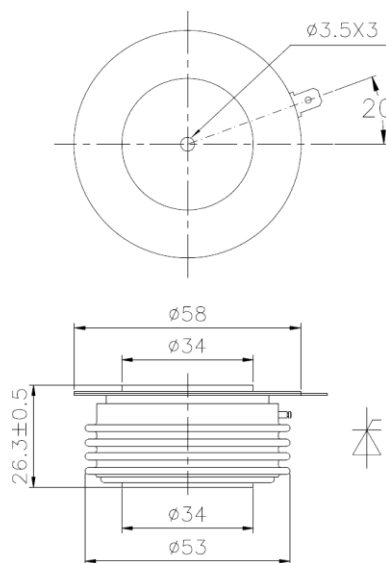

Fig.8

Outline:



Nlps reserves the right to change specifications without notice.