

Features

- Center amplifying gate
- Metal case with ceramic insulator
- Low on-state and switching losses

Typical Applications

- AC controllers
- DC and AC motor control
- Controlled rectifiers

$I_{T(AV)}$ **512A**
 V_{DRM}/V_{RRM} **3100~4200V**
 I_{TSM} **7 kA**
 I^2t **245 10³A²S**



SYMBOL	CHARACTERISTIC	TEST CONDITIONS		T _J (°C)	VALUE			UNIT
					Min	Type	Max	
$I_{T(AV)}$	Mean on-state current	180° half sine wave 50Hz Double side cooled,	T _C =70°C	125			512	A
V_{DRM} V_{RRM}	Repetitive peak off-state voltage Repetitive peak reverse voltage	tp=10ms		125	3100		4200	V
I_{DRM} I_{RRM}	Repetitive peak current	at V_{DRM} at V_{RRM}		125			50	mA
I_{TSM}	Surge on-state current	10ms half sine wave		125			7	kA
I^2t	I^2t for fusing coordination	$V_R=0.6V_{RRM}$					245	A ² s*10 ³
V_{TO}	Threshold voltage			125			1.18	V
r_T	On-state slope resistance						1.50	mΩ
V_{TM}	Peak on-state voltage	$I_{TM}=1100A, F=15kN$		25			2.83	V
dv/dt	Critical rate of rise of off-state voltage	$V_{DM}=0.67V_{DRM}$		125			1000	V/μs
di/dt	Critical rate of rise of on-state current	$V_{DM}= 67\%V_{DRM}$ to800A, Gate pulse $t_r \leq 0.5\mu s$ $I_{GM}=1.5A$		125			100	A/μs
Q_{rr}	Recovery charge	$I_{TM}=800A, tp=1000\mu s, di/dt=-20A/\mu s,$ $V_R =50V$		125		1400		μC
I_{GT}	Gate trigger current			25	35		300	mA
V_{GT}	Gate trigger voltage	$V_A=12V, I_A=1A$			0.8		2.5	V
I_H	Holding current				20		250	mA
V_{GD}	Non-trigger gate voltage	$V_{DM}=0.67V_{DRM}$		125	0.3			V
$R_{th(j-c)}$	Thermal resistance Junction to case	DC: double side cooled Clamping force15kN					0.035	°C /W
$R_{th(c-h)}$	Thermal resistance case to heatsink						0.008	
F_m	Mounting force				10		20	kN
T_{stg}	Stored temperature				-40		140	°C
W_t	Weight					240		g
Outline	P08							

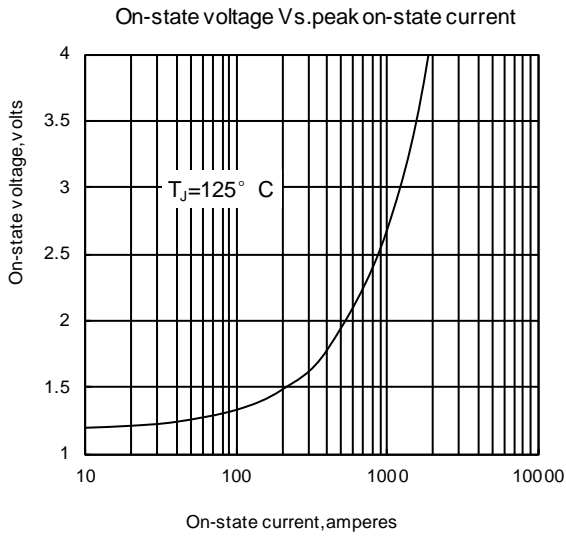

Fig1

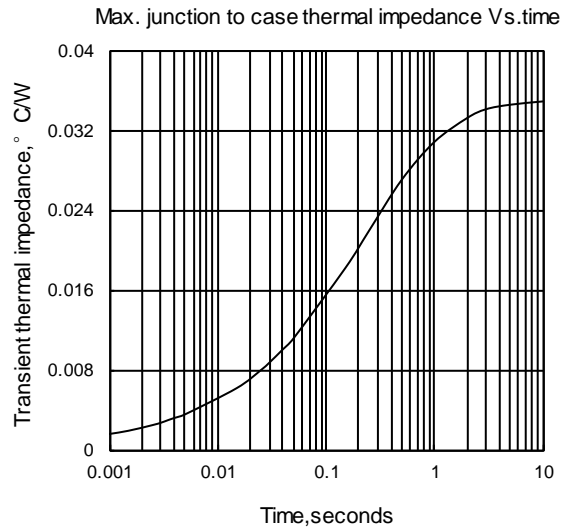

Fig2

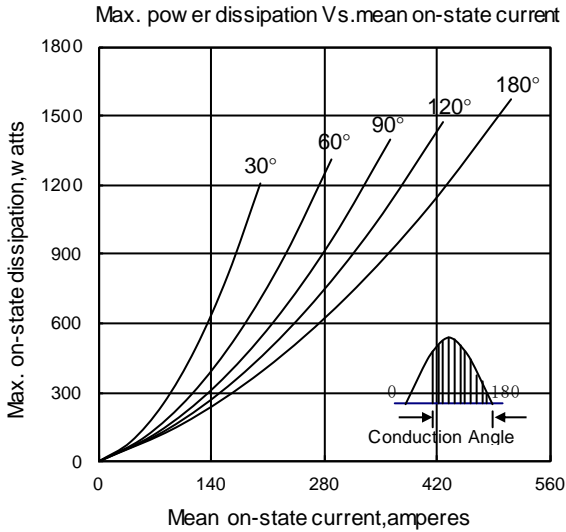

Fig3

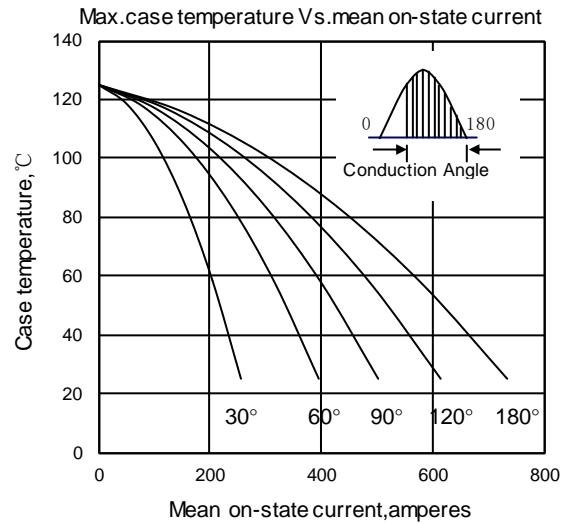

Fig4

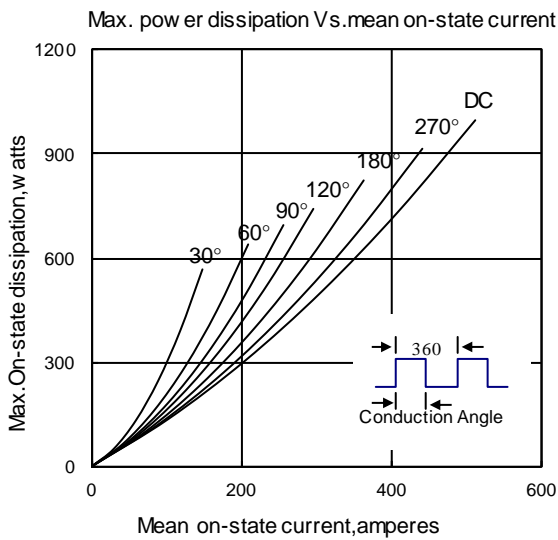

Fig5

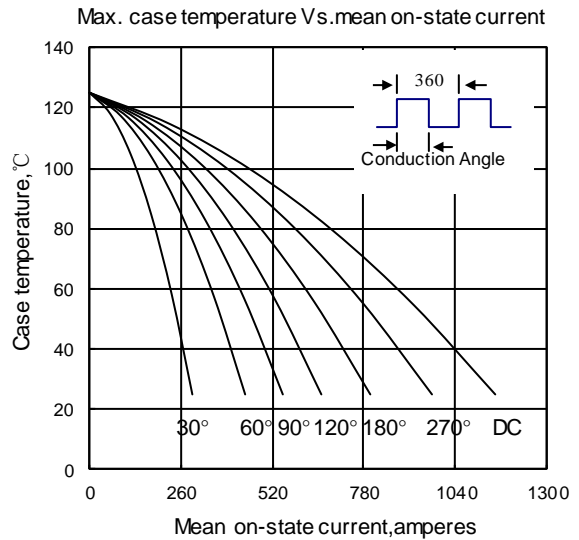

Fig6

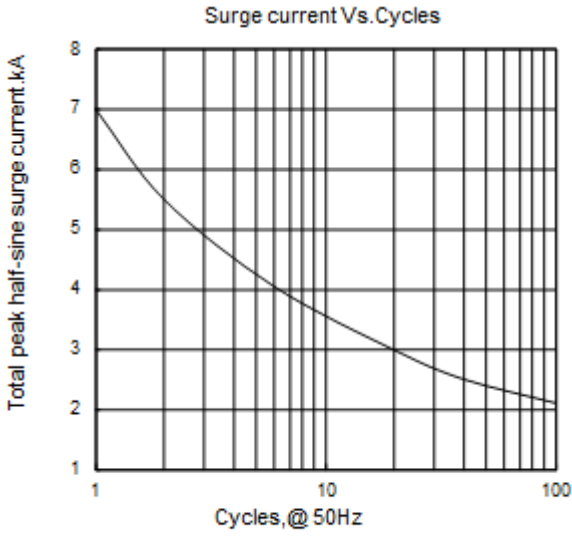

Fig7

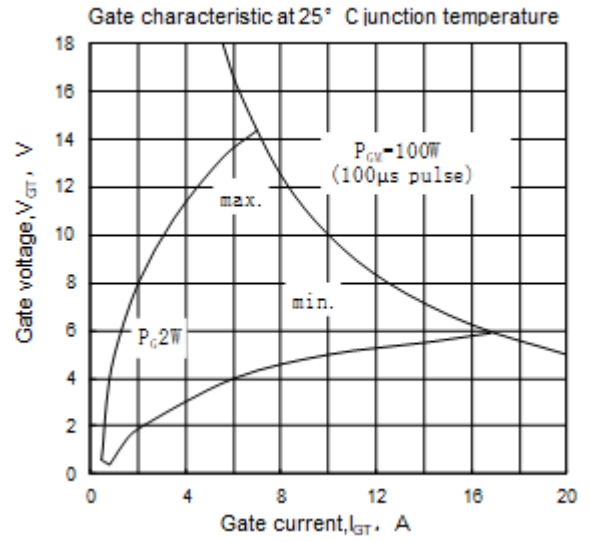

Fig8

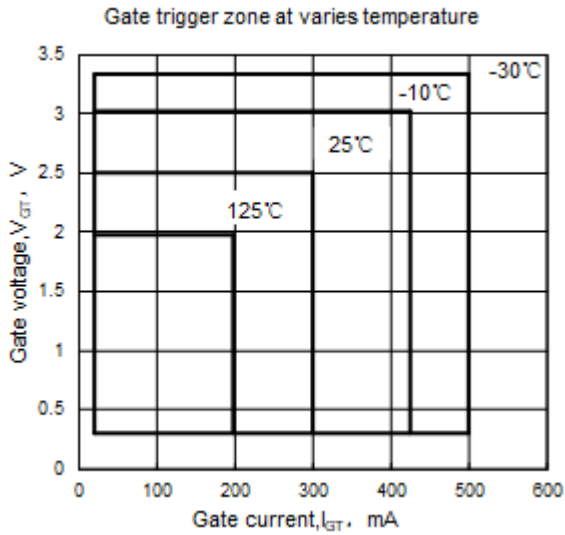
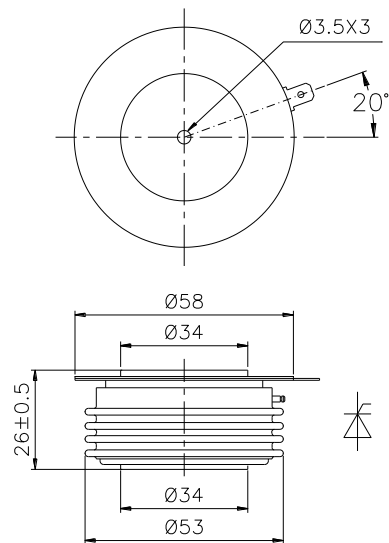

Fig9



Nlps reserves the right to change specifications without notice.