

Features

- Interdigitated amplifying gates
- Fast turn-on and high di/dt
- Low switching losses

Typical Applications

- Inductive heating
- Electronic welders
- Self-commutated inverters

$I_{T(AV)}$	4890A
V_{DRM}/V_{RRM}	1900 ~ 3000V
t_q	40~130μs
I_{TSM}	62 kA
I^2t	19220 10³A²S

SYMBOL	CHARACTERISTIC	TEST CONDITIONS	$T_j(^{\circ}C)$	VALUE			UNIT
				Min	Type	Max	
$I_{T(AV)}$	Mean on-state current	180° half sine wave 50Hz Double side cooled, $T_c=55^{\circ}C$	125			4890	A
V_{DRM} V_{RRM}	Repetitive peak off-state voltage Repetitive peak reverse voltage	$t_p=10ms$	125	1900		3000	V
I_{DRM} I_{RRM}	Repetitive peak current	at V_{DRM} at V_{RRM}	125			250	mA
I_{TSM}	Surge on-state current	10ms half sine wave	125			62	kA
I^2t	I^2t for fusing coordination	$V_R=0.6V_{RRM}$				19220	$A^2s \cdot 10^3$
V_{TO}	Threshold voltage		125			1.30	V
r_T	On-state slope resistance					0.28	m Ω
V_{TM}	Peak on-state voltage	$I_{TM}=5000A, F=90kN$	25			2.90	V
dv/dt	Critical rate of rise of off-state voltage	$V_{DM}=0.67V_{DRM}$	125			1000	V/ μ s
di/dt	Critical rate of rise of on-state current	$V_{DM}=67\%V_{DRM}$ to 4000A Gate pulse $t_r \leq 0.5\mu s$ $I_{GM}=1.5A$ Single pulse	125			1200	A/ μ s
Q_{rr}	Recovery charge	$I_{TM}=2000A, t_p=4000\mu s,$ $di/dt=-20A/\mu s, V_R=100V$	125		2400		μC
t_q	Circuit commutated turn-off time	$I_{TM}=2000A, t_p=4000\mu s, V_R=100V$ $dv/dt=30V/\mu s, di/dt=-20A/\mu s$	125	40		130	μs
I_{GT}	Gate trigger current	$V_A=12V, I_A=1A$	25	40		450	mA
V_{GT}	Gate trigger voltage			0.9		4.5	V
I_H	Holding current			20		1000	mA
I_L	Latching current					1000	mA
V_{GD}	Non-trigger gate voltage	$V_{DM}=67\%V_{DRM}$	125			0.3	V
$R_{th(j-c)}$	Thermal resistance Junction to case	D.C. double side cooled Clamping force 90kN				0.005	$^{\circ}C/W$
$R_{th(c-h)}$	Thermal resistance case to heat sink					0.0015	
F_m	Mounting force			81		108	kN
T_{vj}	Junction temperature			-40		125	$^{\circ}C$
T_{stg}	Stored temperature			-40		140	$^{\circ}C$
W_t	Weight				2000		g
Outline	P21						

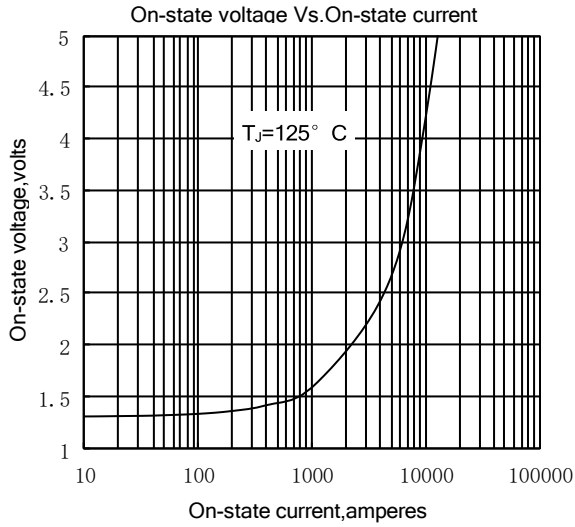

Fig.1

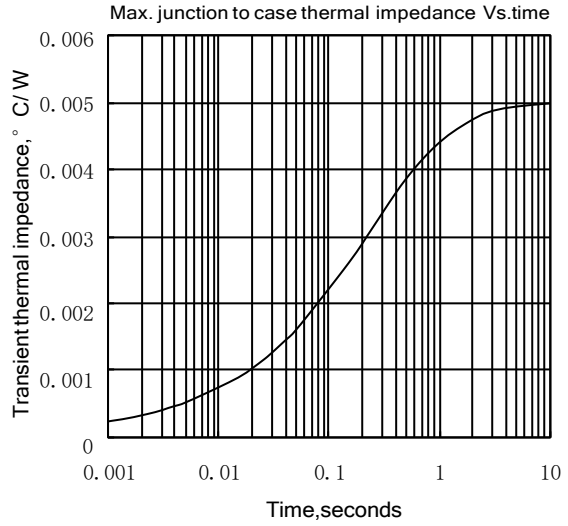

Fig.2

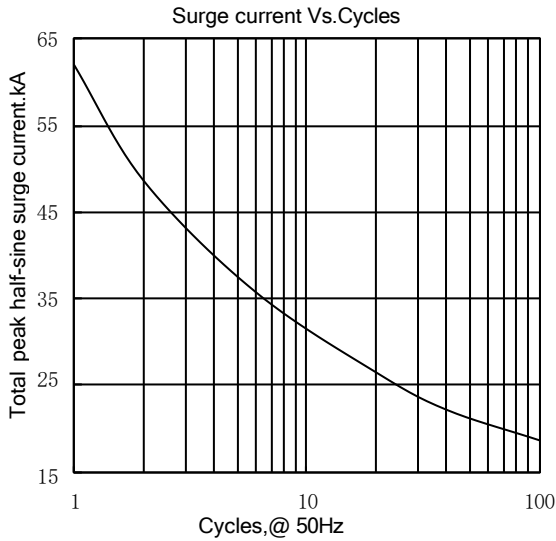

Fig.3

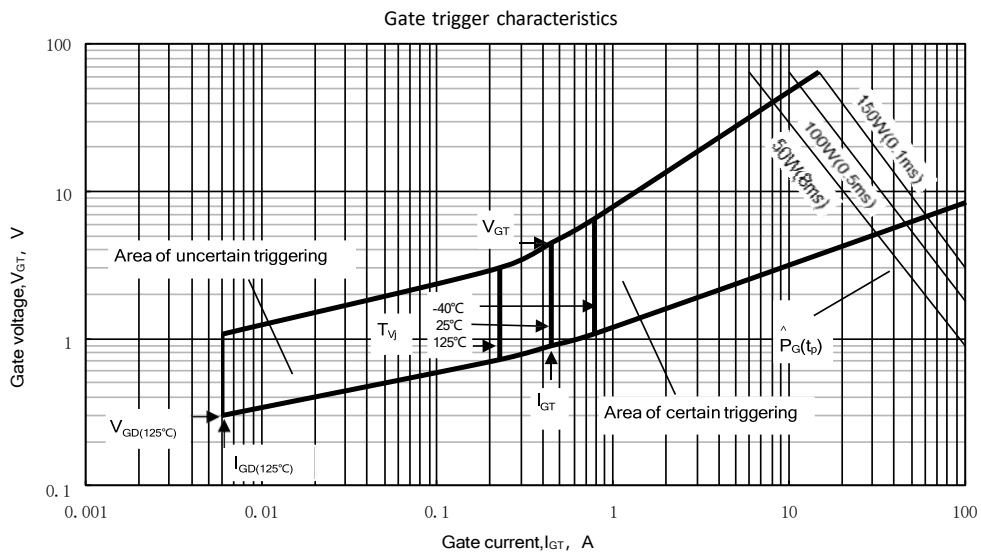
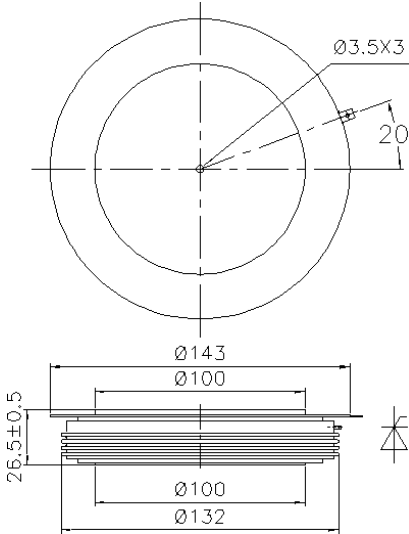

Fig.4

Outline:



Nlps reserves the right to change specifications without notice.