

**Features**

- Low forward voltage drop
- Soft recovery
- Hermetic metal cases with ceramic insulators

**I<sub>F(AV)</sub> 430 A**  
**V<sub>RRM</sub> 200 ~ 1000V**  
**trr 2.0 μs**

**Typical Applications**

- Inverters and choppers
- AC. motor control
- Snubber and free-wheeling diodes

SYMBOL	CHARACTERISTIC	TEST CONDITIONS	T <sub>J</sub> (°C)	VALUE			UNIT	
				Min	Type	Max		
I <sub>F(AV)</sub>	Mean forward current	180° half sine wave 50Hz Double side cooled,	T <sub>C</sub> =55°C	150			560	A
			T <sub>C</sub> =85°C				430	
V <sub>RRM</sub>	Repetitive peak reverse voltage	tp=10ms	150	200		1000	V	
I <sub>RRM</sub>	Repetitive peak current	at V <sub>RRM</sub>	150			16	mA	
I <sub>FSM</sub>	Surge forward current	10ms half sine wave	150			5	kA	
I <sup>2</sup> t	I <sup>2</sup> t for fusing coordination	V <sub>R</sub> =0.6V <sub>RRM</sub>				125		A <sup>2</sup> s*10 <sup>3</sup>
V <sub>FO</sub>	Threshold voltage		150			1.10	V	
r <sub>F</sub>	Forward slope resistance					0.72		mΩ
V <sub>FM</sub>	Peak forward voltage	I <sub>TM</sub> =600A, F=5.0kN	150			2.4	V	
I <sub>rm</sub>	Reverse recovery current	I <sub>TM</sub> =1000A, tp=4000μs, di/dt=-60A/μs, V <sub>R</sub> =100V	150		36		A	
t <sub>rr</sub>	Reverse recovery time				2.0		μs	
Q <sub>rr</sub>	Recovery charge				36	50	μC	
R <sub>th(j-c)</sub>	Thermal resistance Junction to case	D.C. double side cooled Clamping force 5.0kN				0.080	°C/W	
R <sub>th(c-h)</sub>	Thermal resistance case to heat sink					0.020		
F <sub>m</sub>	Mounting force			3.3		5.5	kN	
T <sub>vj</sub>	Junction temperature			-40		150	°C	
T <sub>stg</sub>	Stored temperature			-40		160	°C	
W <sub>t</sub>	Weight				60		g	
Outline	P32							

**Outline:**

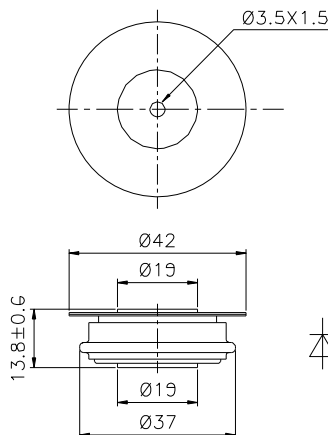

Nlps reserves the right to change specifications without notice.