

Features

- Center amplifying gate
- Metal case with ceramic insulator
- Low on-state and switching losses

Typical Applications

- AC controllers
- DC and AC motor control
- Controlled rectifiers

$I_{T(AV)}$ 320A
 V_{DRM}/V_{RRM} 6600~7200V
 I_{TSM} 4.0 kA
 I^2t 80 10³A²S



SYMBOL	CHARACTERISTIC	TEST CONDITIONS	T _J (°C)	VALUE			UNIT
				Min	Type	Max	
$I_{T(AV)}$	Mean on-state current	180° half sine wave 50Hz Double side cooled	T _C =70°C	125		320	A
V_{DRM} V_{RRM}	Repetitive peak off-state voltage Repetitive peak reverse voltage	tp=10ms	125	6600		7200	V
I_{DRM} I_{RRM}	Repetitive peak current	at V_{DRM} at V_{RRM}	125			150	mA
I_{TSM}	Surge on-state current	10ms half sine wave	125			4.0	kA
I^2t	I^2t for fusing coordination	$V_R=0.6V_{RRM}$	125			80	A ² s*10 ³
V_{TO}	Threshold voltage		125			1.13	V
r_T	On-state slope resistance		125			3.10	mΩ
V_{TM}	Peak on-state voltage	$I_{TM}=500A, F=15kN$	125			2.90	V
dv/dt	Critical rate of rise of off-state voltage	$V_{DM}=0.67V_{DRM}$	125			2000	V/μs
di/dt	Critical rate of rise of on-state current	$V_{DM}= 67\%V_{DRM}$ to1300A, Gate pulse $t_r \leq 0.5\mu s$ $I_{GM}=1.5A$	125			100	A/μs
Q_{rr}	Recovery charge	$I_{TM}=1000A, tp=2000\mu s, di/dt=-5A/\mu s,$ $V_R =50V$	125		2500		μC
I_{GT}	Gate trigger current	$V_A=12V, I_A=1A$	25	30		300	mA
V_{GT}	Gate trigger voltage			0.8		3.0	V
I_H	Holding current			20		200	mA
V_{GD}	Non-trigger gate voltage	$V_{DM}=0.67V_{DRM}$	125	0.3			V
$R_{th(j-c)}$	Thermal resistance Junction to case	DC: double side cooled Clamping force15kN				0.045	°C /W
$R_{th(c-h)}$	Thermal resistance case to heatsink					0.008	°C /W
F_m	Mounting force			10	15	20	kN
T_{stg}	Stored temperature			-40		140	°C
W_t	Weight				300		g
Outline	P23						

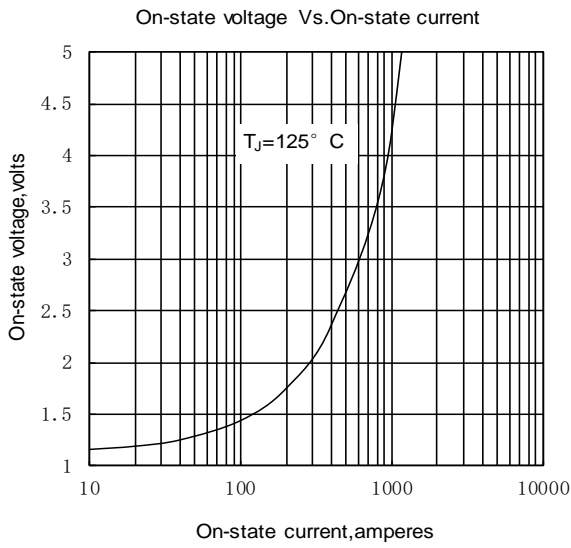

Fig. 1

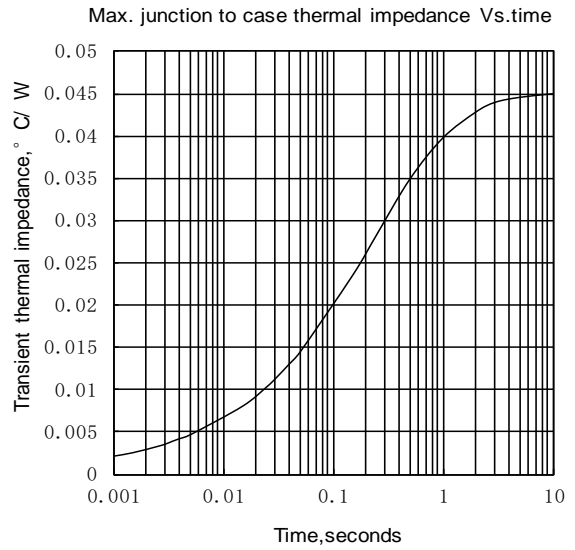

Fig. 2

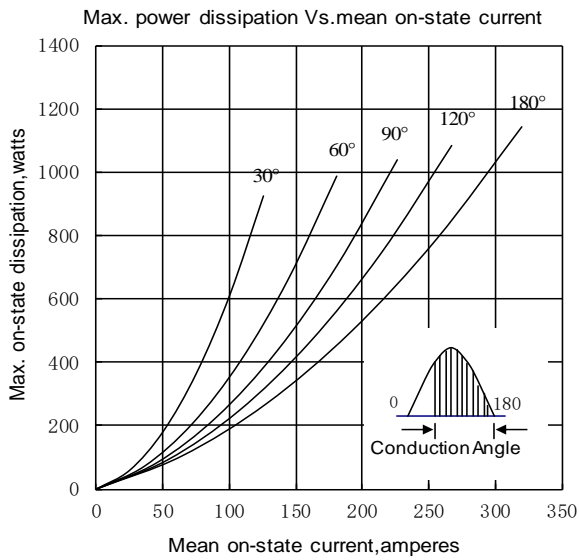

Fig. 3

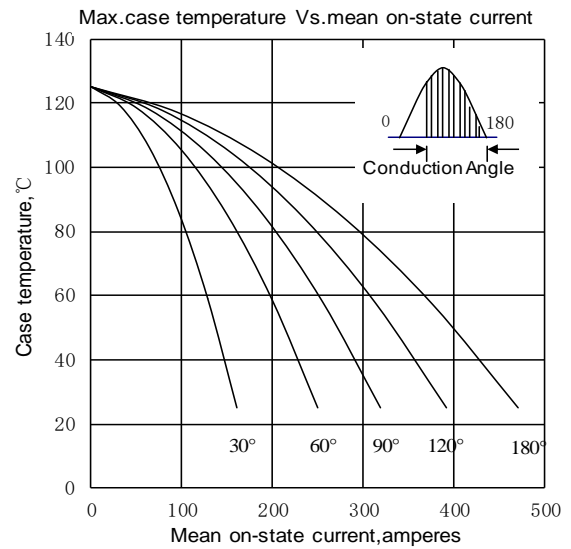

Fig. 4

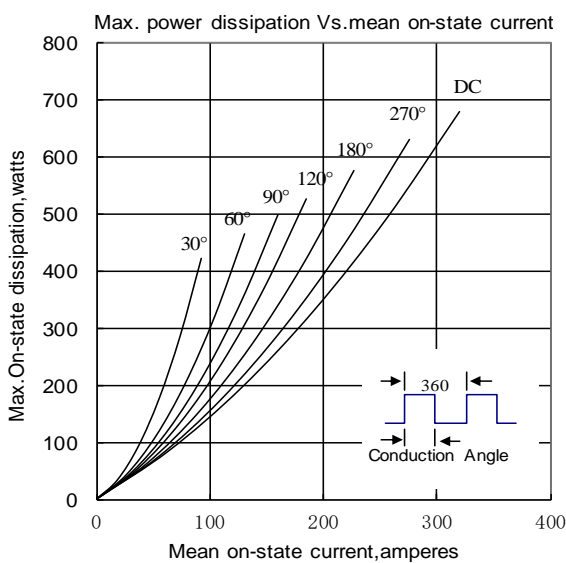

Fig. 5

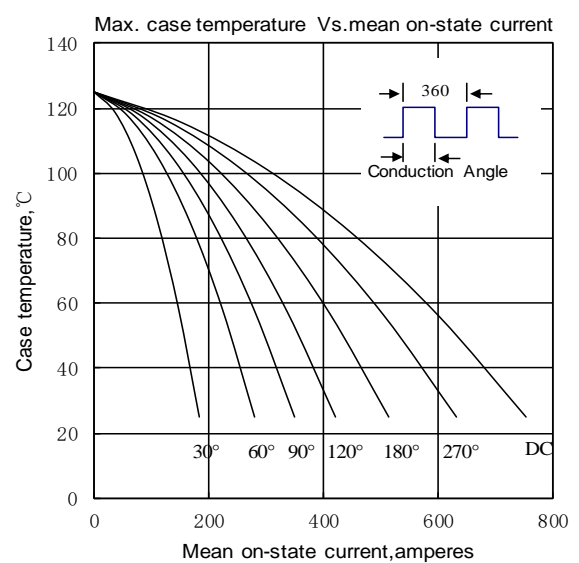

Fig. 6

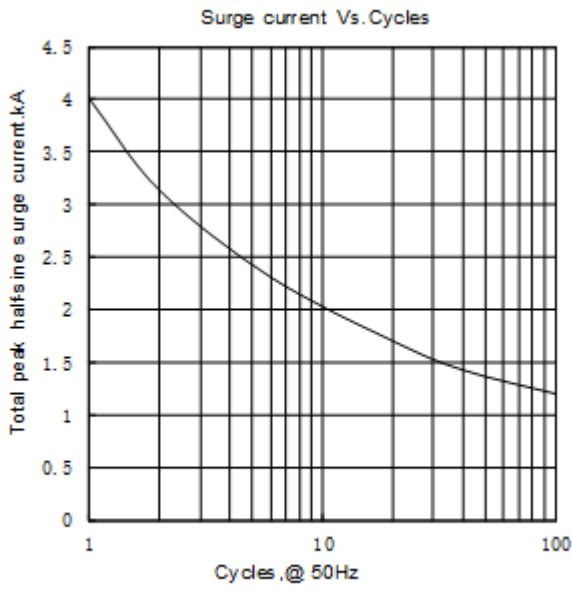

Fig.7

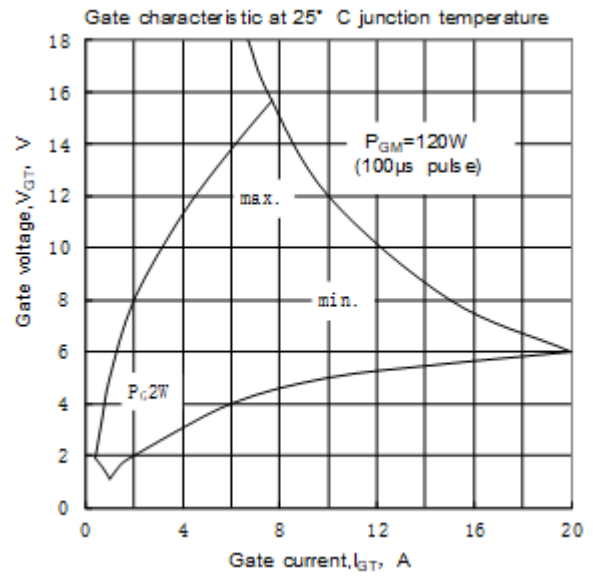

Fig.8

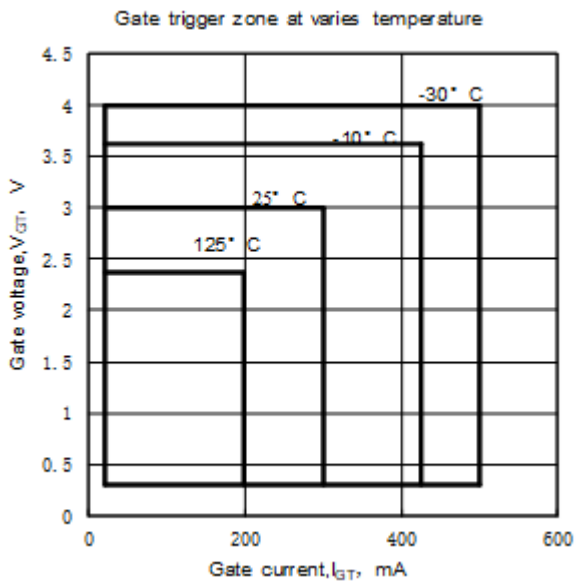
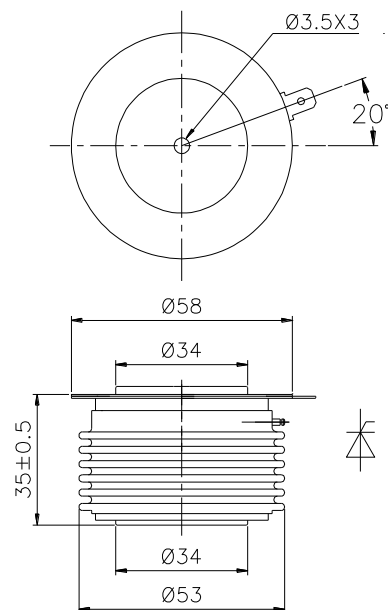

Fig.9



Nlps reserves the right to change specifications without notice.