

Features

- Interdigitated amplifying gates
- Fast turn-on and high di/dt
- Low switching losses

Typical Applications

- Inductive heating
- Electronic welders
- Self-commutated inverters

$I_{T(AV)}$	2240A
V_{DRM}/V_{RRM}	4100~5200V
t_q	60~150μs
I_{TSM}	21 kA
I^2t	2205 10³A²S



SYMBOL	CHARACTERISTIC	TEST CONDITIONS		T _j (°C)	VALUE			UNIT
					Min	Type	Max	
$I_{T(AV)}$	Mean on-state current	180° half sine wave 50Hz Double side cooled,	T _c =55°C	125			2240	A
V_{DRM} V_{RRM}	Repetitive peak off-state voltage Repetitive peak reverse voltage	tp=10ms		125	4100		5200	V
I_{DRM} I_{RRM}	Repetitive peak current	at V_{DRM} at V_{RRM}		125			250	mA
I_{TSM}	Surge on-state current	10ms half sine wave		125			21	kA
I^2t	I^2t for fusing coordination	$V_R=0.6V_{RRM}$					2205	A ² s*10 ³
V_{TO}	Threshold voltage			125			1.68	V
r_T	On-state slope resistance						0.26	mΩ
V_{TM}	Peak on-state voltage	$I_{TM}=2000A, F=70kN$		125			3.20	V
dv/dt	Critical rate of rise of off-state voltage	$V_{DM}=0.67V_{DRM}$		125			500	V/ μ s
di/dt	Critical rate of rise of on-state current	$V_{DM}=67\%V_{DRM}$, to4000A Gate pulse $t_r \leq 0.5\mu s$ $I_{GM}=1.5A$		125			1200	A/ μ s
Q_{rr}	Recovery charge	$I_{TM}=2000A, tp=2000\mu s$, $di/dt=-20A/\mu s, V_R=50V$		125		4000		μC
t_q	Circuit commutated turn-off time	$I_{TM}=2000A, tp=2000\mu s, V_R=50V$ $dv/dt=30V/\mu s, di/dt=-60A/\mu s$		125	60		150	μs
I_{GT}	Gate trigger current	$V_A=12V, I_A=1A$		25	50		300	mA
V_{GT}	Gate trigger voltage				0.8		3.5	V
I_H	Holding current				40		1000	mA
V_{GD}	Non-trigger gate voltage	$V_{DM}=67\%V_{DRM}$		125	0.25			V
$R_{th(j-c)}$	Thermal resistance Junction to case	DC double side cooled Clamping force 40kN					0.010	°C/W
$R_{th(c-h)}$	Thermal resistance case to heat sink						0.003	
F_m	Mounting force				35		47	kN
T_{stg}	Stored temperature				-40		140	°C
W_i	Weight					880		g
Outline	P66							

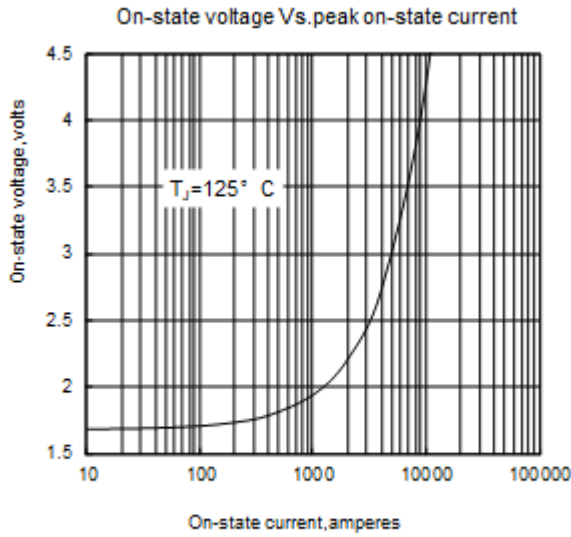

Fig1

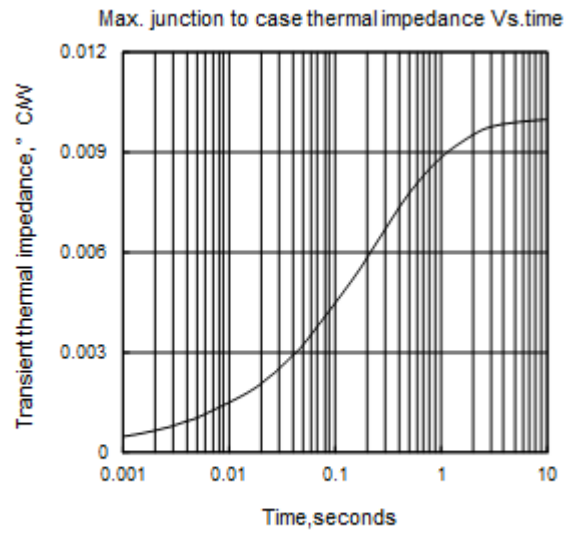

Fig2

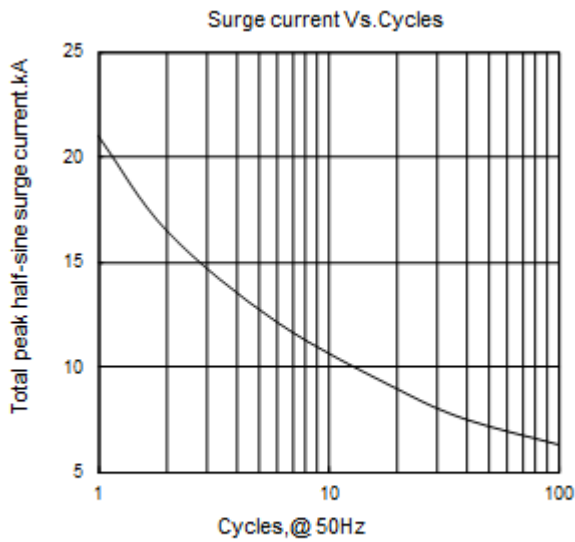

Fig3

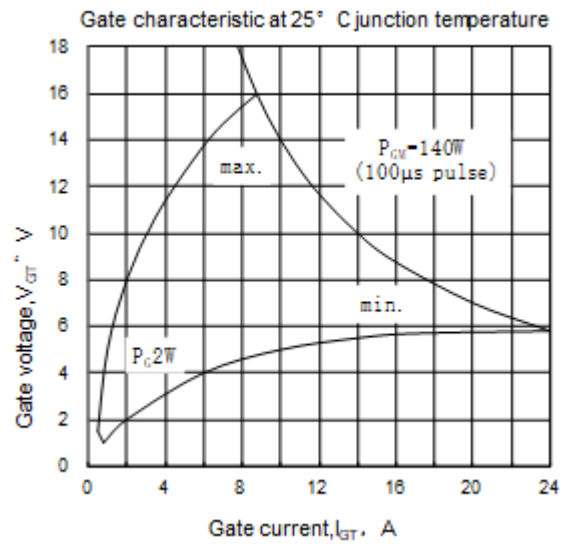

Fig4

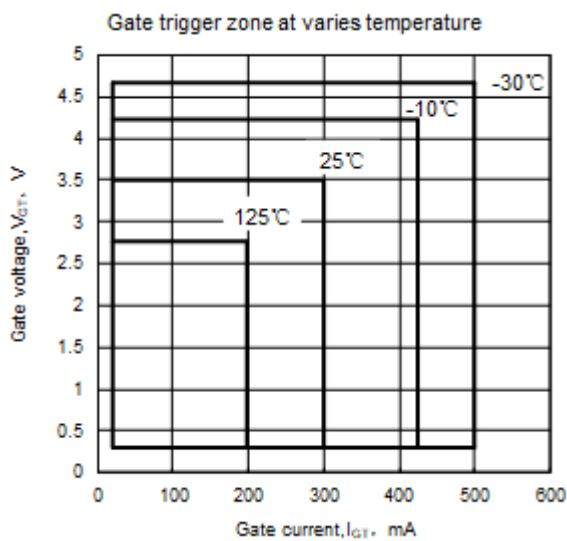
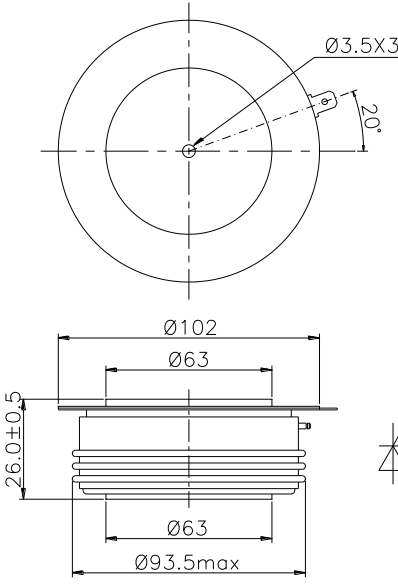

Fig5



Nlps reserves the right to change specifications without notice.