

Features

- Interdigitated amplifying gates
- Fast turn-on and high di/dt
- Low switching losses

Typical Applications

- Inductive heating
- Electronic welders
- Self-commutated inverters

$I_{T(AV)}$ 2160A
 V_{DRM}/V_{RRM} 1900~2500V
 t_q 40~80 μ s
 I_{TSM} 23 kA
 I^2t 2645 10³A²S



SYMBOL	CHARACTERISTIC	TEST CONDITIONS	T _i (°C)	VALUE			UNIT
				Min	Type	Max	
$I_{T(AV)}$	Mean on-state current	180° half sine wave 50Hz Double side cooled, T _C =55°C	125			2160	A
V_{DRM} V_{RRM}	Repetitive peak off-state voltage Repetitive peak reverse voltage	tp=10ms	125	1900		2500	V
I_{DRM} I_{RRM}	Repetitive peak current	at V_{DRM} at V_{RRM}	125			160	mA
I_{TSM}	Surge on-state current	10ms half sine wave	125			23	kA
I^2t	I^2t for fusing coordination	$V_R=0.6V_{RRM}$				2645	A ² s*10 ³
V_{TO}	Threshold voltage		125			1.48	V
r_T	On-state slope resistance					0.23	mΩ
V_{TM}	Peak on-state voltage	$I_{TM}=4000A, F=35kN$	125			2.40	V
dv/dt	Critical rate of rise of off-state voltage	$V_{DM}=0.67V_{DRM}$	125			500	V/ μ s
di/dt	Critical rate of rise of on-state current	$V_{DM}=67\%V_{DRM}$ to 3000A Gate pulse $t_r \leq 0.5\mu s$ $I_{GM}=1.5A$	125			1200	A/ μ s
Q_{rr}	Recovery charge	$I_{TM}=2000A, tp=2000\mu s,$ $di/dt=-60A/\mu s, V_R=50V$	125		1400		μC
t_q	Circuit commutated turn-off time	$I_{TM}=2000A, tp=2000\mu s, V_R=50V$ $dv/dt=30V/\mu s, di/dt=-60A/\mu s$	125	40		80	μs
I_{GT}	Gate trigger current	$V_A=12V, I_A=1A$	25	40		450	mA
V_{GT}	Gate trigger voltage			0.9		4.5	V
I_H	Holding current			20		1000	mA
V_{GD}	Non-trigger gate voltage	$V_{DM}=67\%V_{DRM}$	125	0.3			V
$R_{th(j-c)}$	Thermal resistance Junction to case	DC double side cooled Clamping force 35kN				0.012	°C/W
$R_{th(c-h)}$	Thermal resistance case to heat sink					0.003	
F_m	Mounting force			30		40	kN
T_{stg}	Stored temperature			-40		140	°C
W_t	Weight				880		g
Outline	P15						

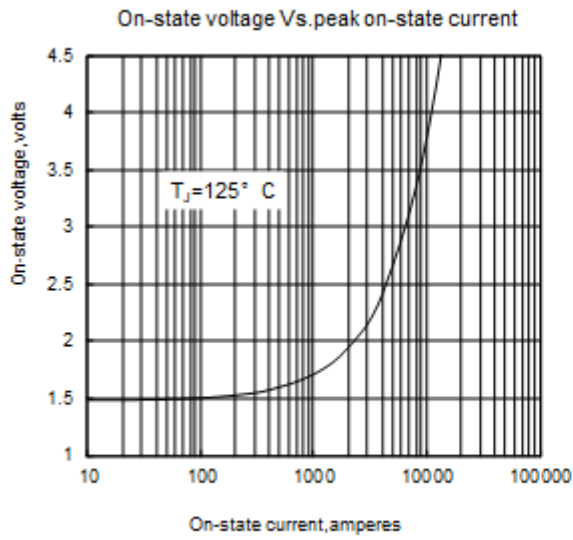

Fig1

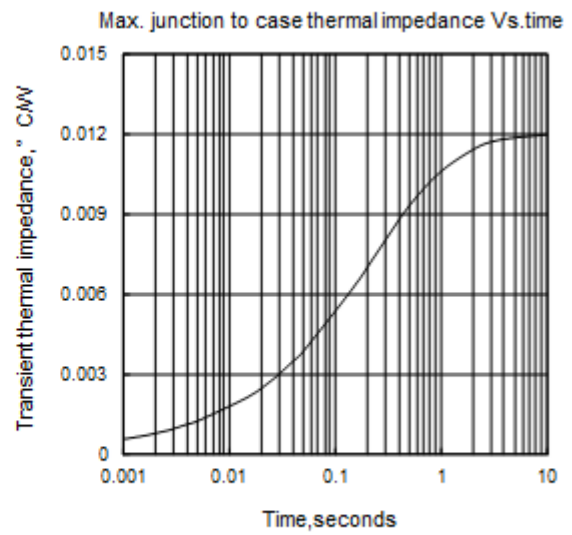

Fig2

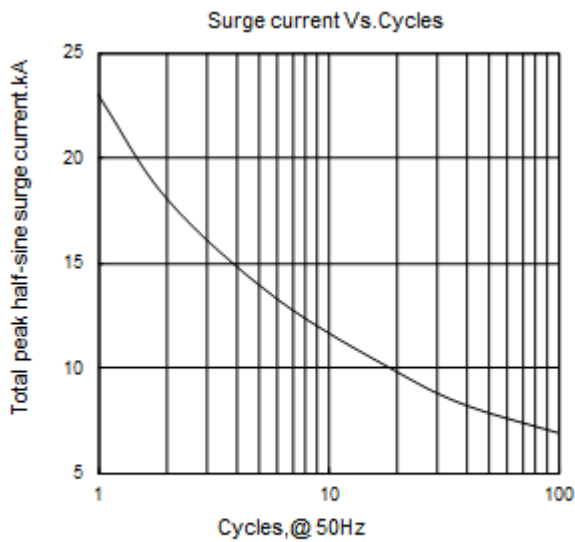

Fig3

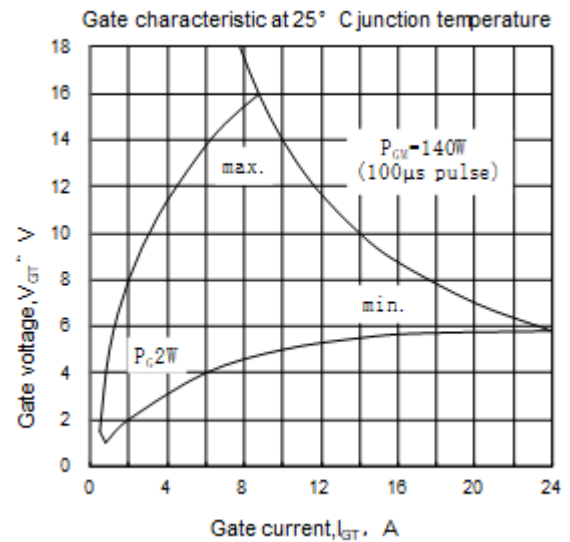

Fig4

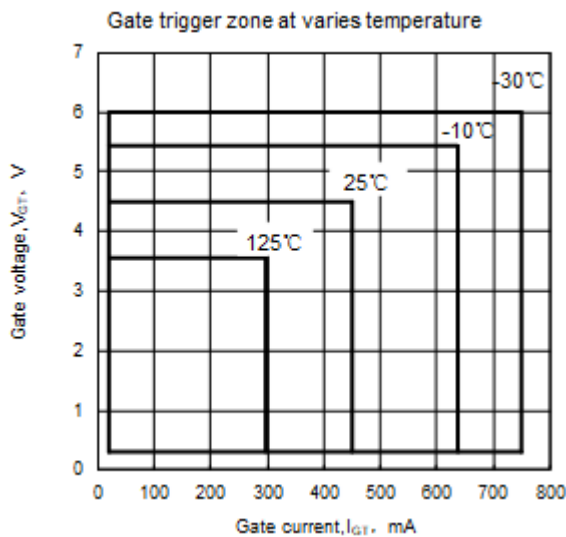
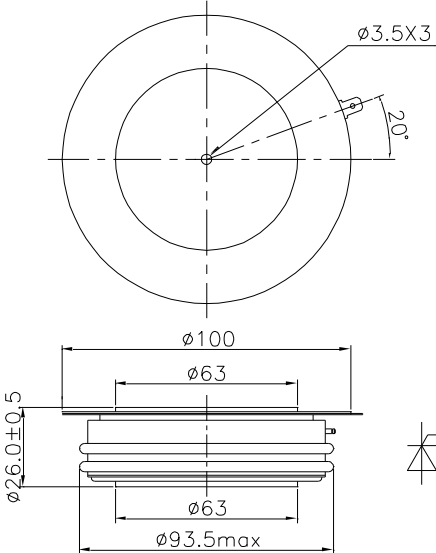

Fig5



Nlps reserves the right to change specifications without notice.