

Features

- Interdigitated amplifying gates
- Fast turn-on and high di/dt
- Low switching losses

Typical Applications

- Inductive heating
- Electronic welders
- Self-commutated inverters

$I_{T(AV)}$	2040A
V_{DRM}/V_{RRM}	3100 ~ 4000V
t_q	50~100μs
I_{TSM}	23 kA
I^2t	2645 10³A²s

SYMBOL	CHARACTERISTIC	TEST CONDITIONS		$T_j(^{\circ}C)$	VALUE			UNIT
					Min	Type	Max	
$I_{T(AV)}$	Mean on-state current	180° half sine wave 50Hz Double side cooled,	$T_c=55^{\circ}C$	125			2040	A
V_{DRM} V_{RRM}	Repetitive peak off-state voltage Repetitive peak reverse voltage	tp=10ms		125	3100		4000	V
I_{DRM} I_{RRM}	Repetitive peak current	at V_{DRM} at V_{RRM}		125			200	mA
I_{TSM}	Surge on-state current	10ms half sine wave		125			23	kA
I^2t	I^2t for fusing coordination						2645	A ² s*10 ³
V_{TO}	Threshold voltage			125			1.89	V
r_T	On-state slope resistance						0.42	m Ω
V_{TM}	Peak on-state voltage	$I_{TM}=2000A, F=40kN$		25			3.40	V
dv/dt	Critical rate of rise of off-state voltage	$V_{DM}=0.67V_{DRM}$		125			1000	V/ μ s
di/dt	Critical rate of rise of on-state current	$V_{DM}=67\%V_{DRM}$ Gate pulse $t_r \leq 0.5\mu s$ $I_{GM}=1.5A$ Single pulse		125			1000	A/ μ s
Q_{rr}	Recovery charge	$I_{TM}=2000A, tp=4000\mu s,$ $di/dt=-20A/\mu s, V_R=100V$		125		2200		μC
t_q	Circuit commutated turn-off time	$I_{TM}=2000A, tp=4000\mu s, V_R=100V$ $dv/dt=30V/\mu s, di/dt=-20A/\mu s$		125	50		100	μs
I_{GT}	Gate trigger current	$V_A=12V, I_A=1A.$		25	40		300	mA
V_{GT}	Gate trigger voltage				0.9		3.5	V
I_H	Holding current				20		1000	mA
I_L	Latching current						1000	mA
V_{GD}	Non-trigger gate voltage	$V_{DM}=67\%V_{DRM}$		125			0.3	V
$R_{th(j-c)}$	Thermal resistance Junction to case	D.C. double side cooled					0.010	$^{\circ}C/W$
$R_{th(c-h)}$	Thermal resistance case to heat sink	Clamping force 35kN.					0.003	
F_m	Mounting force				35		47	kN
T_{vj}	Junction temperature				-40		125	$^{\circ}C$
T_{stg}	Stored temperature				-40		140	$^{\circ}C$
W_t	Weight					1100		g
Outline	P17							

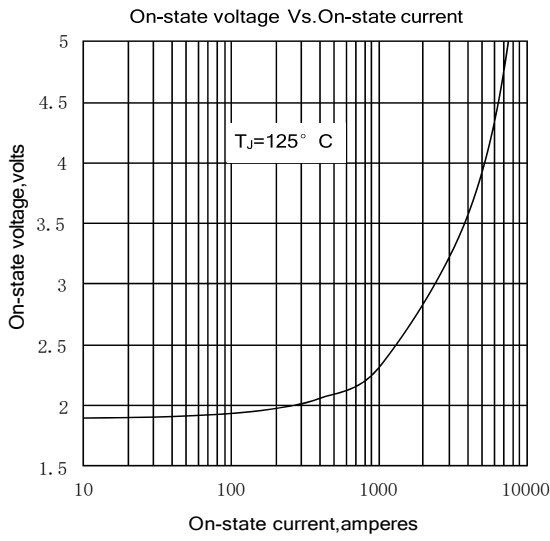

Fig. 1

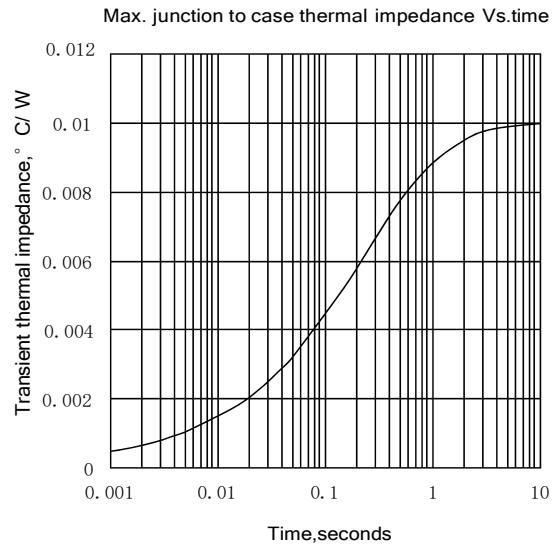

Fig. 2

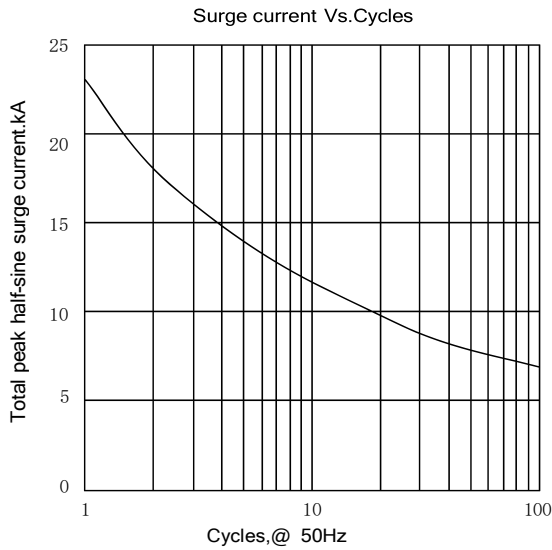

Fig. 3

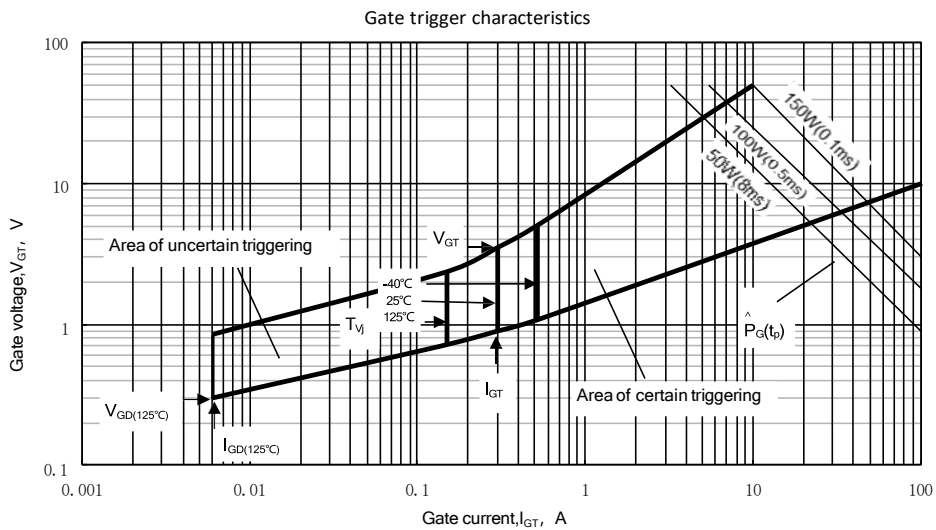
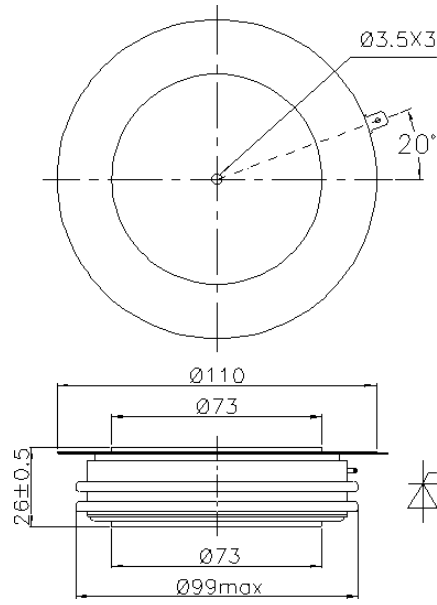

Fig. 4

Outline:



Nlps reserves the right to change specifications without notice.