

Features

- Interdigitated amplifying gates
- Fast turn-on and high di/dt
- Low switching losses

Typical Applications

- Inductive heating
- Electronic welders
- Self-commutated inverters

$I_{T(AV)}$	1840A
V_{DRM}/V_{RRM}	1900~2500V
t_q	40~80μs
I_{TSM}	21 kA
I^2t	2205 10³A²S

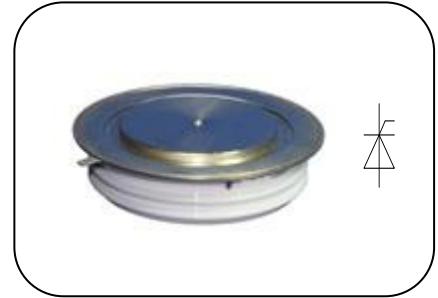

SYMBOL	CHARACTERISTIC	TEST CONDITIONS	T _J (°C)	VALUE			UNIT
				Min	Type	Max	
$I_{T(AV)}$	Mean on-state current	180° half sine wave 50Hz Double side cooled,	T _C =55°C	125		1840	A
V_{DRM} V_{RRM}	Repetitive peak off-state voltage Repetitive peak reverse voltage	tp=10ms	125	1900		2500	V
I_{DRM} I_{RRM}	Repetitive peak current	at V_{DRM} at V_{RRM}	125			140	mA
I_{TSM}	Surge on-state current	10ms half sine wave	125			21	kA
I^2t	I^2t for fusing coordination					2205	A ² s*10 ³
V_{TO}	Threshold voltage		125			1.43	V
r_T	On-state slope resistance		125			0.33	mΩ
V_{TM}	Peak on-state voltage	I _{TM} =3600A, F=32kN	125			2.62	V
dv/dt	Critical rate of rise of off-state voltage	V _{DM} =0.67V _{DRM}	125			500	V/μs
di/dt	Critical rate of rise of on-state current	V _{DM} = 67%V _{DRM} to2500A Gate pulse t _r ≤0.5μs I _{GM} =1.5A	125			1200	A/μs
Q _{rr}	Recovery charge	I _{TM} =1000A, tp=2000μs, di/dt=-60A/μs, V _R =50V	125		1360		μC
t _q	Circuit commutated turn-off time	I _{TM} =1000A, tp=2000μs, V _R =50V dv/dt=30V/μs, di/dt=-60A/μs	125	40		80	μs
I _{GT}	Gate trigger current	V _A =12V, I _A =1A	25	40		450	mA
V _{GT}	Gate trigger voltage			0.9		4.5	V
I _H	Holding current			20		800	mA
V _{GD}	Non-trigger gate voltage	V _{DM} =67%V _{DRM}	125	0.3			V
R _{th(j-c)}	Thermal resistance Junction to case	DC: double side cooled Clamping force 32kN				0.0130	°C/W
R _{th(c-h)}	Thermal resistance case to heat sink					0.0035	
F _m	Mounting force			27		34	kN
T _{stg}	Stored temperature			-40		140	°C
W _t	Weight					820	g
Outline	P15						

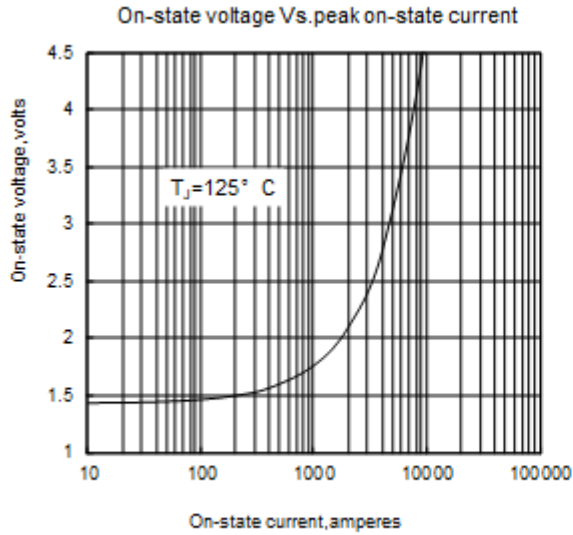

Fig1

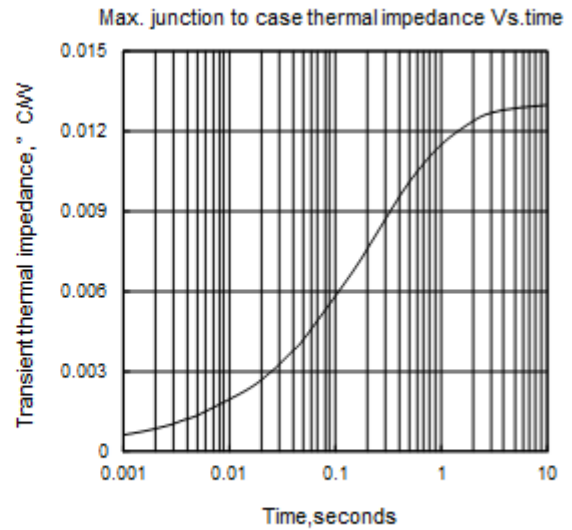

Fig2

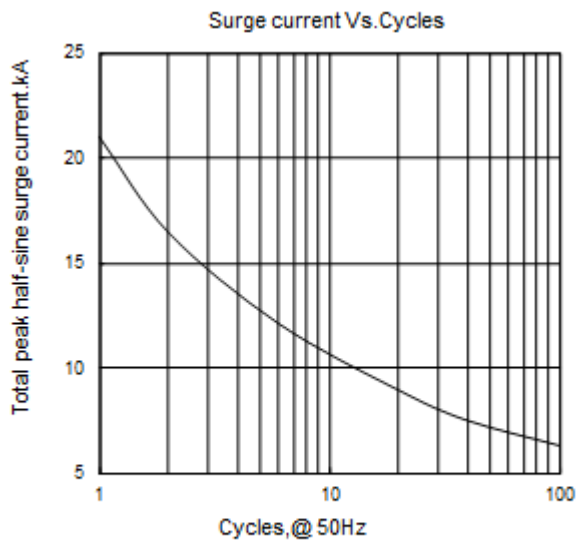

Fig3

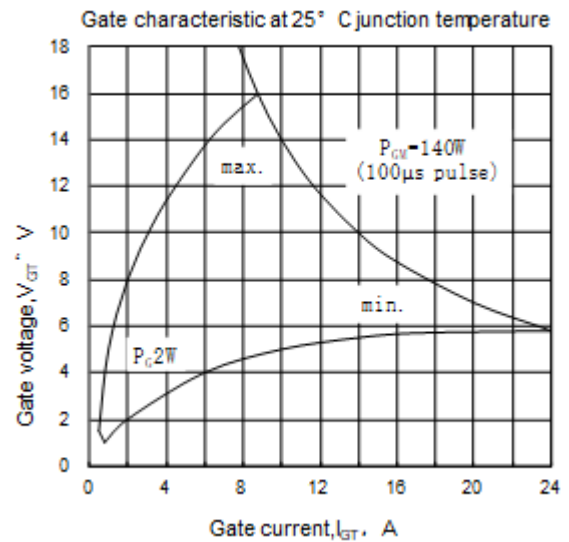

Fig4

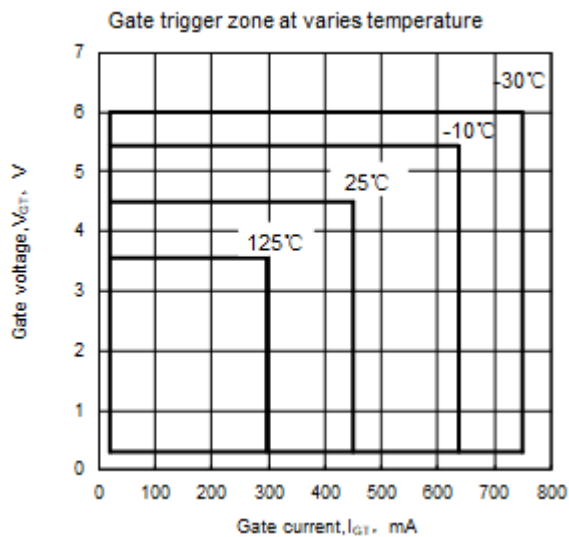
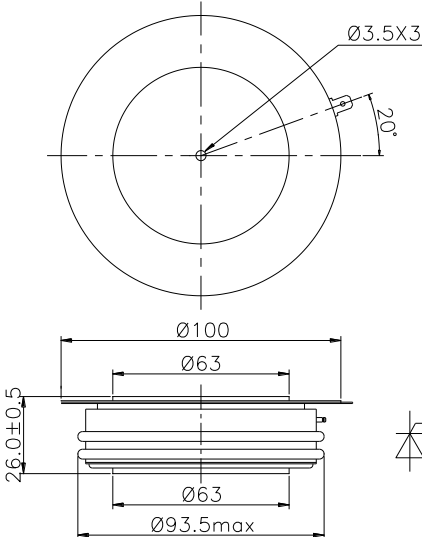

Fig5



Nlps reserves the right to change specifications without notice.