

Features

- Interdigitated amplifying gates
- Fast turn-on and high di/dt
- Low switching losses

Typical Applications

- Inductive heating
- Electronic welders
- Self-commutated inverters

$I_{T(AV)}$	1750A
V_{DRM}/V_{RRM}	800 ~ 1800V
t_q	18~50μs
I_{TSM}	18 kA
I^2t	1620 10³A²S

SYMBOL	CHARACTERISTIC	TEST CONDITIONS		T _J (°C)	VALUE			UNIT
					Min	Type	Max	
$I_{T(AV)}$	Mean on-state current	180° half sine wave 50Hz Double side cooled,	T _C =55°C	125			1750	A
V_{DRM} V_{RRM}	Repetitive peak off-state voltage Repetitive peak reverse voltage	tp=10ms		125	800		1800	V
I_{DRM} I_{RRM}	Repetitive peak current	at V_{DRM} at V_{RRM}		125			120	mA
I_{TSM}	Surge on-state current	10ms half sine wave		125			18	kA
I^2t	I^2t for fusing coordination	$V_R=0.6V_{RRM}$					1620	A ² s*10 ³
V_{TO}	Threshold voltage			125			1.48	V
r_T	On-state slope resistance						0.28	m Ω
V_{TM}	Peak on-state voltage	$I_{TM}=3000A, F=28kN$		25			3.15	V
dv/dt	Critical rate of rise of off-state voltage	$V_{DM}=0.67V_{DRM}$		125			1000	V/ μ s
di/dt	Critical rate of rise of on-state current	$V_{DM}=67\%V_{DRM}$ to 2500A, Gate pulse $t_r \leq 0.5\mu s$ $I_{GM}=1.5A$ Single pulse		125			1200	A/ μ s
Q_{rr}	Recovery charge	$I_{TM}=1000A, tp=4000\mu s,$ $di/dt=-20A/\mu s, V_R=100V$		125		800		μC
t_q	Circuit commutated turn-off time	$I_{TM}=1000A, tp=4000\mu s, V_R=100V$ $dv/dt=30V/\mu s, di/dt=-20A/\mu s$		125	18		50	μs
I_{GT}	Gate trigger current	$V_A=12V, I_A=1A$		25	40		300	mA
V_{GT}	Gate trigger voltage				0.9		3.5	V
I_H	Holding current				20		500	mA
I_L	Latching current						1000	mA
V_{GD}	Non-trigger gate voltage	$V_{DM}=67\%V_{DRM}$		125			0.3	V
$R_{th(f-c)}$	Thermal resistance Junction to case	D.C. double side cooled Clamping force 28kN					0.016	°C/W
$R_{th(c-h)}$	Thermal resistance case to heat sink						0.004	
F_m	Mounting force				21		30	kN
T_{vj}	Junction temperature				-40		125	°C
T_{stg}	Stored temperature				-40		140	°C
W_t	Weight					650		g
Outline	P12							

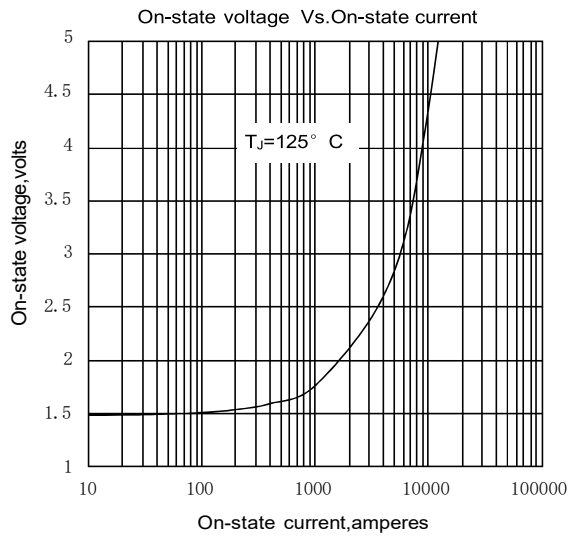

Fig. 1

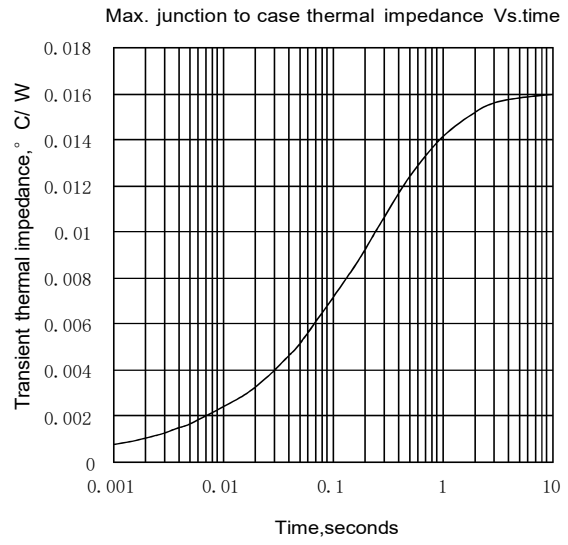

Fig. 2

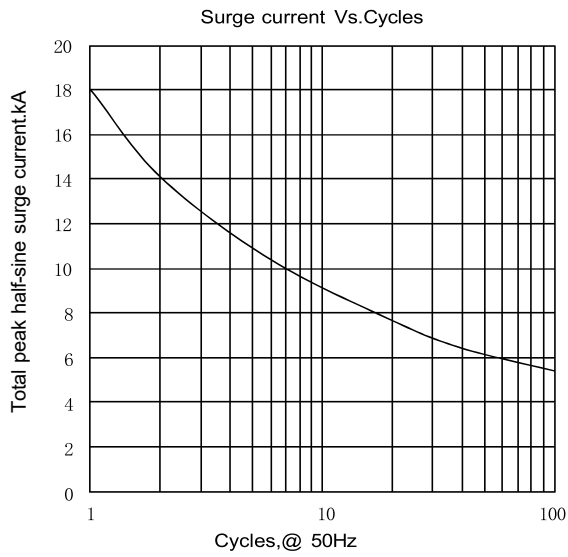
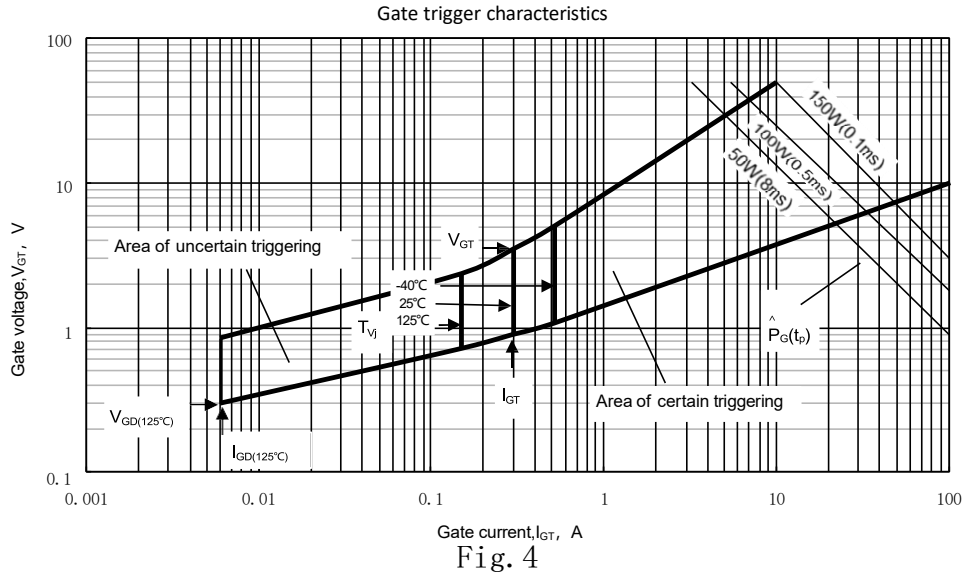
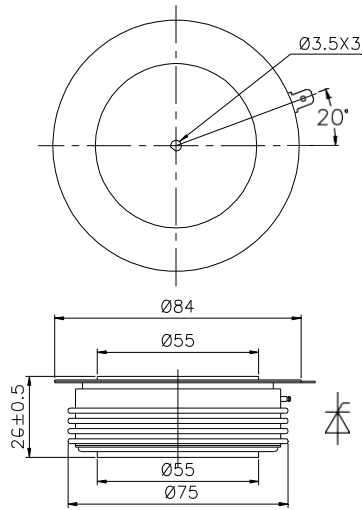

Fig. 3



Outline:



Nlps reserves the right to change specifications without notice.