

Features

- Center amplifying gate
- Metal case with ceramic insulator
- Low on-state and switching losses

Typical Applications

- AC controllers
- DC and AC motor control
- Controlled rectifiers

$I_{T(AV)}$ **1500 A**
 V_{DRM}/V_{RRM} **5600-6500V**
 I_{TSM} **22 kA**
 I^2t **2420 10³A²S**



SYMBOL	CHARACTERISTIC	TEST CONDITIONS	T _J (°C)	VALUE			UNIT
				Min	Type	Max	
I _{T(AV)}	Mean on-state current	180° half sine wave 50Hz Double side cooled, T _C =70°C	125			1500	A
V _{DRM} V _{RRM}	Repetitive peak off-state voltage Repetitive peak reverse voltage	tp=10ms	125	5600		6500	V
I _{DRM} I _{RRM}	Repetitive peak current	at V _{DRM} at V _{RRM}	125			600	mA
I _{TSM}	Surge on-state current	10ms half sine wave V _R =0.6V _{RRM}	125			22	kA
I ² t	I ² t for fusing coordination					2420	A ² s*10 ³
V _{TO}	Threshold voltage		125			1.20	V
r _T	On-state slope resistance					0.63	mΩ
V _{TM}	Peak on-state voltage	I _{TM} =1500A, F=40kN	125			2.12	V
dv/dt	Critical rate of rise of off-state voltage	V _{DM} =0.67V _{DRM}	125			2000	V/μs
di/dt	Critical rate of rise of on-state current	V _{DM} = 67%V _{DRM} to 3000A, Gate pulse tr ≤0.5μs IGM= 1.5A	125			250	A/μs
Q _{rr}	Recovery charge	I _{TM} =2000A, tp=2000μs, di/dt=-5A/μs, V _R =50V	125		3500		μC
I _{GT}	Gate trigger current	V _A =12V, I _A =1A	25	40		300	mA
V _{GT}	Gate trigger voltage			0.8		3.0	V
I _H	Holding current			25		200	mA
V _{GD}	Non-trigger gate voltage	V _{DM} =67%V _{DRM}	125	0.3			V
R _{th(j-c)}	Thermal resistance Junction to case	DC: double side cooled Clamping force 40.0kN				0.010	°C/W
R _{th(c-h)}	Thermal resistance case to heatsink					0.003	°C/W
F _m	Mounting force			35	40	47	kN
T _{stg}	Stored temperature			-40		140	°C
W _t	Weight				880		g
Outline	P14						

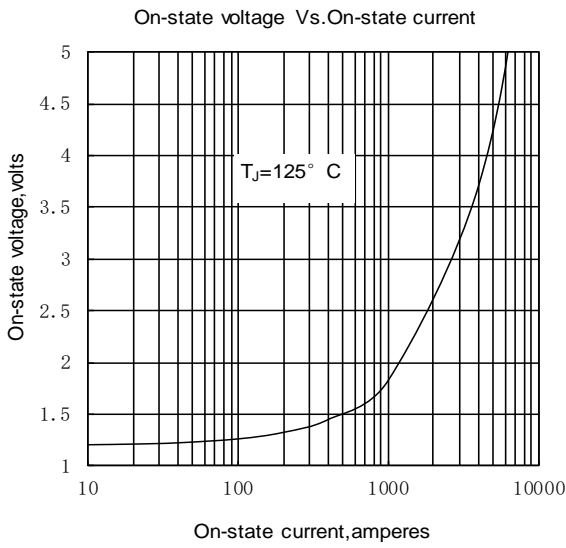

Fig.1

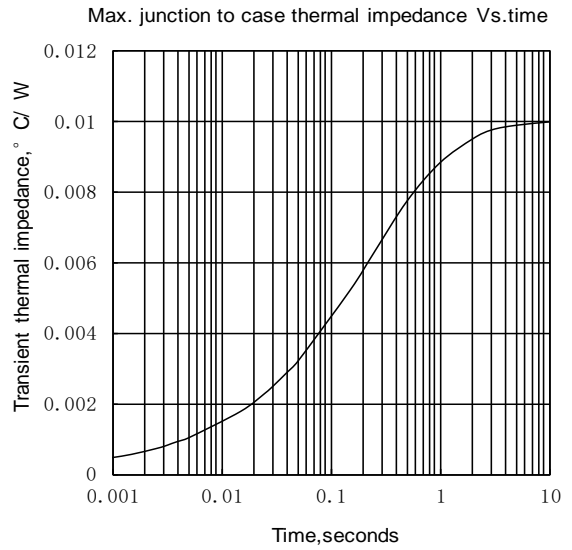

Fig.2

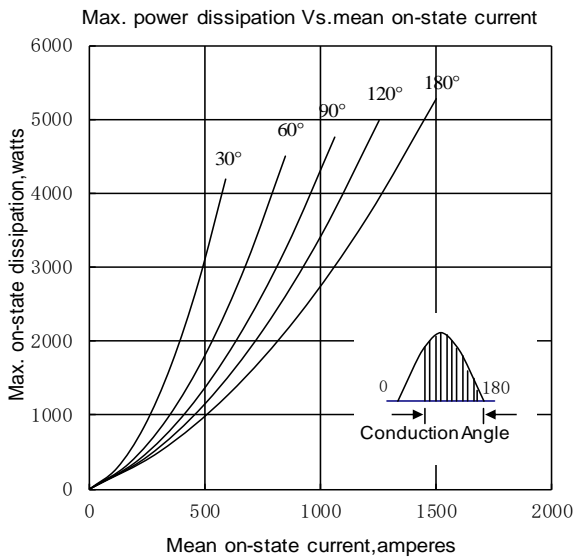

Fig.3

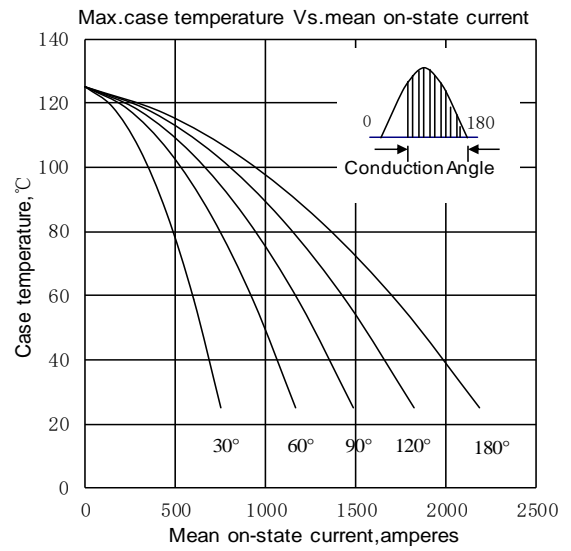

Fig.4

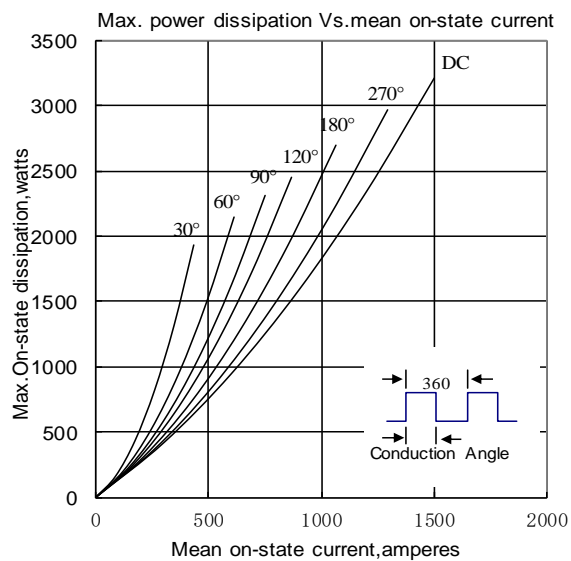

Fig.5

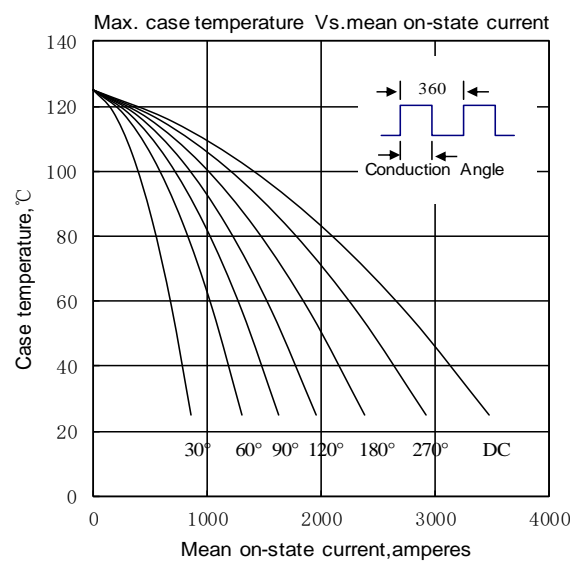

Fig.6

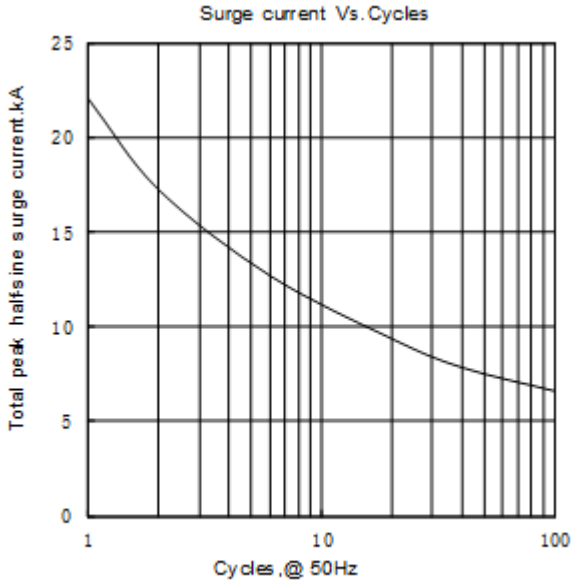

Fig.7

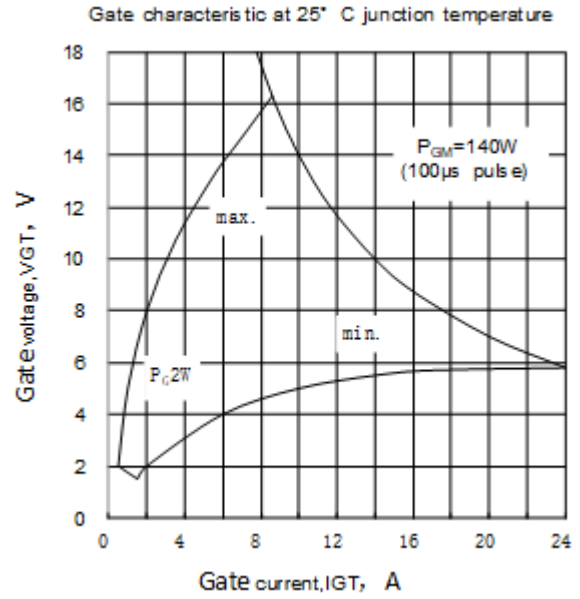

Fig.8

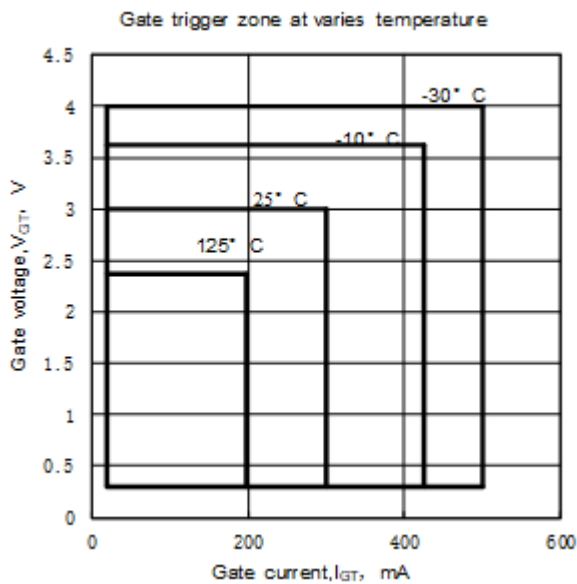
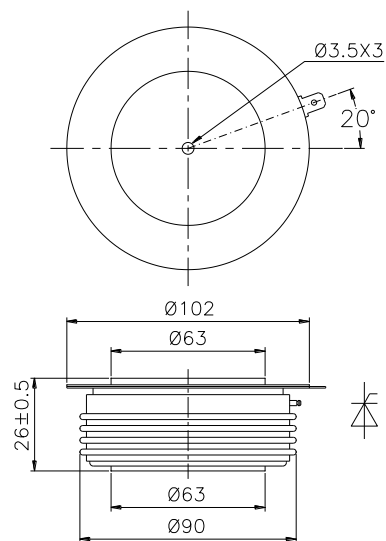

Fig.9



Nlps reserves the right to change specifications without notice.