

Features

- Center amplifying gate
- Metal case with ceramic insulator
- Low on-state and switching losses

$I_{T(AV)}$ 1340A
 V_{DRM}/V_{RRM} 400 ~ 1000V
 I_{TSM} 20 kA
 I^2t 2000 $10^3 A^2s$

Typical Applications

- AC controllers
- DC and AC motor control
- Controlled rectifiers

SYMBOL	CHARACTERISTIC	TEST CONDITIONS		$T_j(^{\circ}C)$	VALUE			UNIT
					Min	Type	Max	
$I_{T(AV)}$	Mean on-state current	180° half sine wave 50Hz Double side cooled	$T_C=70^{\circ}C$	125			1340	A
V_{DRM} V_{RRM}	Repetitive peak off-state voltage Repetitive peak reverse voltage	tp=10ms		125	400		1000	V
I_{DRM} I_{RRM}	Repetitive peak current	at V_{DRM} at V_{RRM}		125			60	mA
I_{TSM}	Surge on-state current	10ms half sine wave, $V_R=0.6V_{RRM}$		125			20	kA
I^2t	I^2t for fusing coordination						2000	$A^2s \cdot 10^3$
V_{TO}	Threshold voltage			125			0.88	V
r_T	On-state slope resistance						0.25	mΩ
V_{TM}	Peak on-state voltage	$I_{TM}=3000A, F=21kN$		25			1.80	V
dv/dt	Critical rate of rise of off-state voltage	$V_{DM}=0.67V_{DRM}$		125			1000	V/μs
di/dt	Critical rate of rise of on-state current	$V_{DM}=67\%V_{DRM}$ to 1500A, Gate pulse $t_r \leq 0.5\mu s$ $I_{GM}=1.5A$		125			150	A/μs
Q_{rr}	Recovery charge	$I_{TM}=1000A, tp=4000\mu s, di/dt=-20A/\mu s,$ $V_R=100V$		125		1200		μC
I_{GT}	Gate trigger current	$V_A=12V, I_A=1A$		25	40		300	mA
V_{GT}	Gate trigger voltage				0.8		3.0	V
I_H	Holding current				20		250	mA
I_L	Latching current						500	mA
V_{GD}	Non-trigger gate voltage	$V_{DM}=67\%V_{DRM}$		125			0.3	V
$R_{th(j-c)}$	Thermal resistance Junction to case	D.C. double side cooled Clamping force 21kN					0.024	$^{\circ}C/W$
$R_{th(c-h)}$	Thermal resistance case to heatsink						0.006	
F_m	Mounting force				18		25	kN
T_{vj}	Junction temperature				-40		125	$^{\circ}C$
T_{stg}	Stored temperature				-40		140	$^{\circ}C$
W_t	Weight					380		g
Outline	P10							

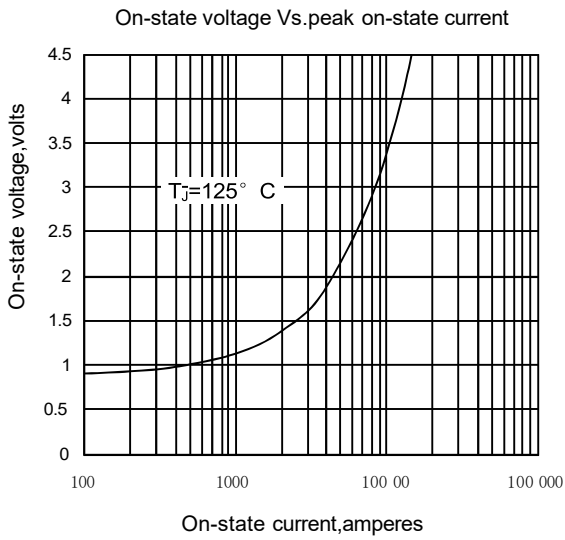

Fig1

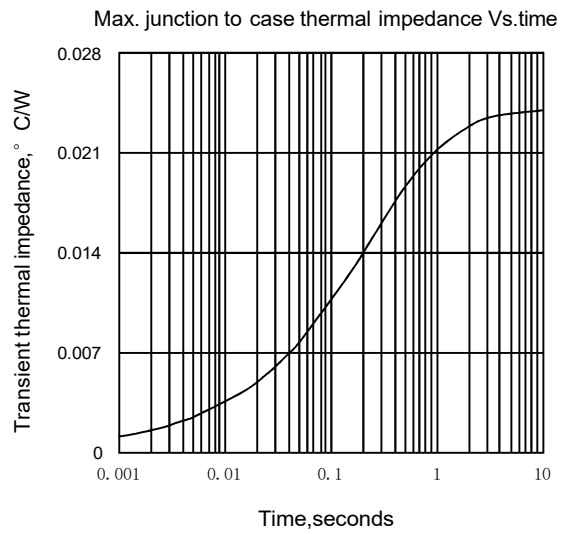

Fig2

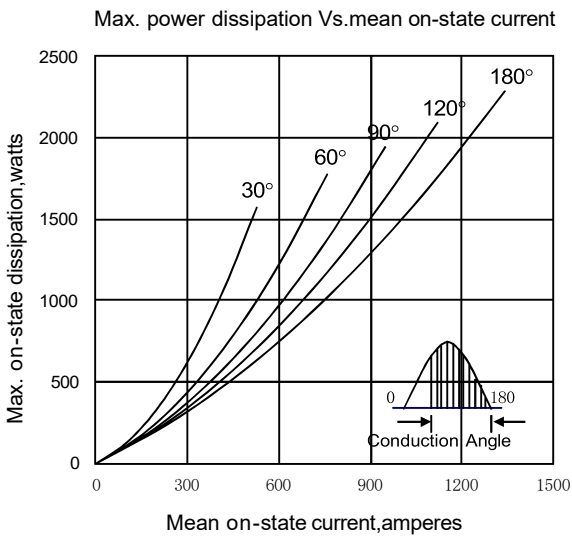

Fig3

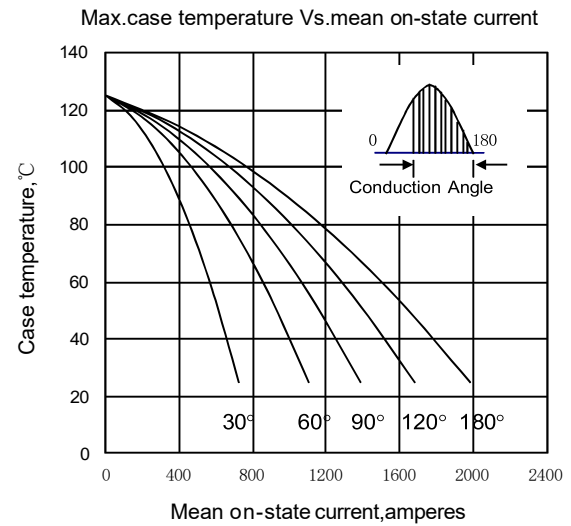

Fig4

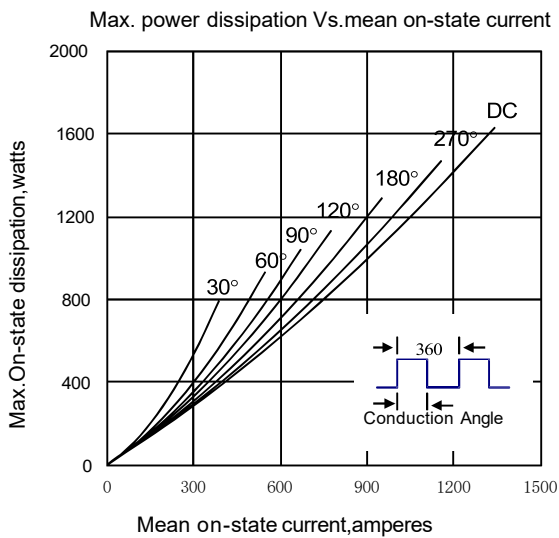

Fig5

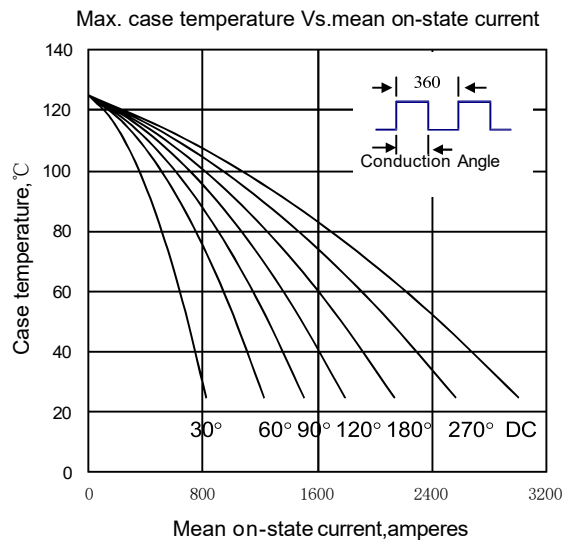

Fig6

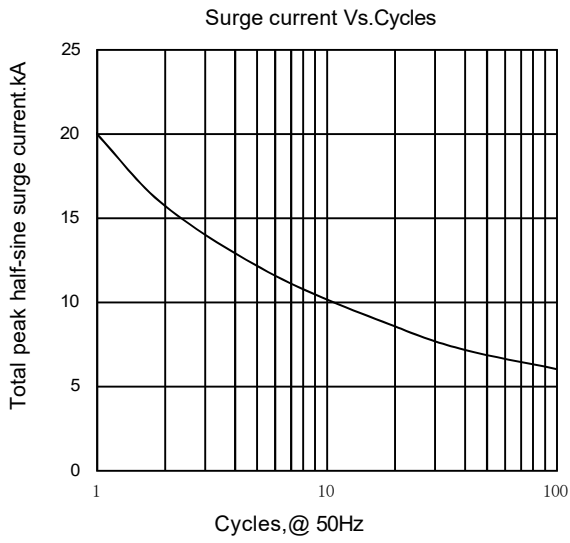

Fig7

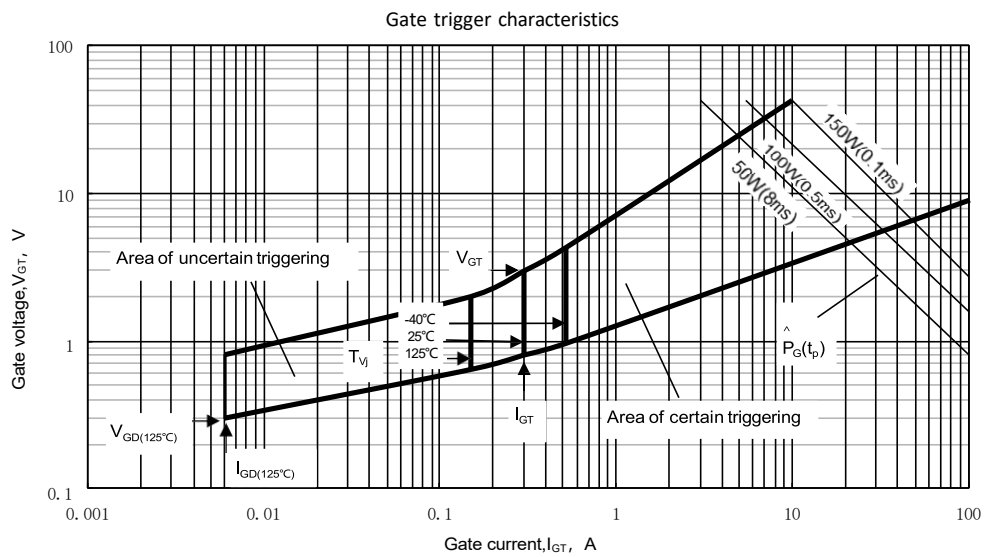
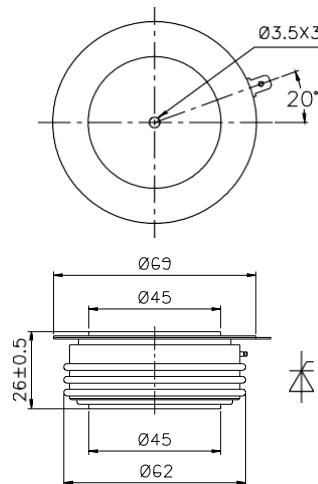

Fig. 8

Outline:



Nlps reserves the right to change specifications without notice.