

Features

- Interdigitated amplifying gates
- Fast turn-on and high di/dt
- Low switching losses

Typical Applications

- Inductive heating
- Electronic welders
- Self-commutated inverters

$I_{T(AV)}$	1330A
V_{DRM}/V_{RRM}	800 ~ 1800V
t_q	18~50μs
I_{TSM}	14 kA
I^2t	980 10³A²S

SYMBOL	CHARACTERISTIC	TEST CONDITIONS	T _j (°C)	VALUE			UNIT
				Min	Type	Max	
$I_{T(AV)}$	Mean on-state current	180° half sine wave 50Hz Double side cooled, T _C =55°C	125			1330	A
V_{DRM} V_{RRM}	Repetitive peak off-state voltage Repetitive peak reverse voltage	tp=10ms	125	800		1800	V
I_{DRM} I_{RRM}	Repetitive peak current	at V_{DRM} at V_{RRM}	125			80	mA
I_{TSM}	Surge on-state current	10ms half sine wave	125			14	kA
I^2t	I^2t for fusing coordination	$V_R=0.6V_{RRM}$				980	A ² s*10 ³
V_{TO}	Threshold voltage		125			1.56	V
r_T	On-state slope resistance					0.33	mΩ
V_{TM}	Peak on-state voltage	$I_{TM}=3000A, F=24kN$	25			3.15	V
dv/dt	Critical rate of rise of off-state voltage	$V_{DM}=0.67V_{DRM}$	125			1000	V/ μ s
di/dt	Critical rate of rise of on-state current	$V_{DM}=67\%V_{DRM}$ to 1600A, Gate pulse $t_r \leq 0.5\mu s$ $I_{GM}=1.5A$ Single pulse	125			1200	A/ μ s
Q_{rr}	Recovery charge	$I_{TM}=1000A, tp=4000\mu s,$ $di/dt=-20A/\mu s, V_R=100V$	125		750		μC
t_q	Circuit commutated turn-off time	$I_{TM}=1000A, tp=4000\mu s, V_R=100V$ $dv/dt=30V/\mu s, di/dt=-20A/\mu s$	125	18		50	μs
I_{GT}	Gate trigger current	$V_A=12V, I_A=1A$	25	40		300	mA
V_{GT}	Gate trigger voltage			0.9		3.0	V
I_H	Holding current			20		500	mA
I_L	Latching current					500	mA
V_{GD}	Non-trigger gate voltage	$V_{DM}=67\%V_{DRM}$	125			0.3	V
$R_{th(j-c)}$	Thermal resistance Junction to case	D.C. double side cooled Clamping force 24kN				0.020	°C/W
$R_{th(c-h)}$	Thermal resistance case to heat sink					0.005	
F_m	Mounting force			19		26	kN
T_{vj}	Junction temperature			-40		125	°C
T_{stg}	Stored temperature			-40		130	°C
W_t	Weight				440		g
Outline	P11						

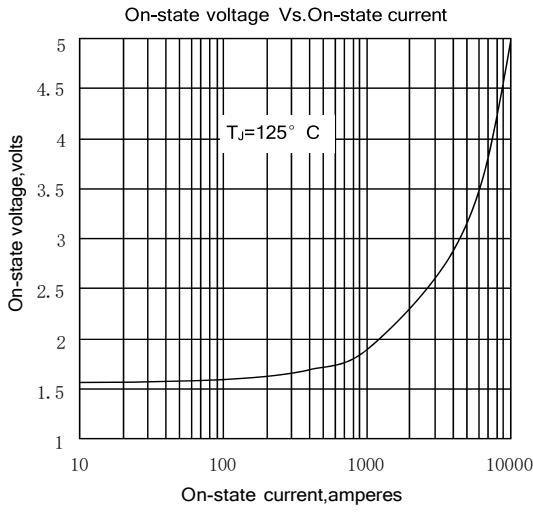

Fig. 1

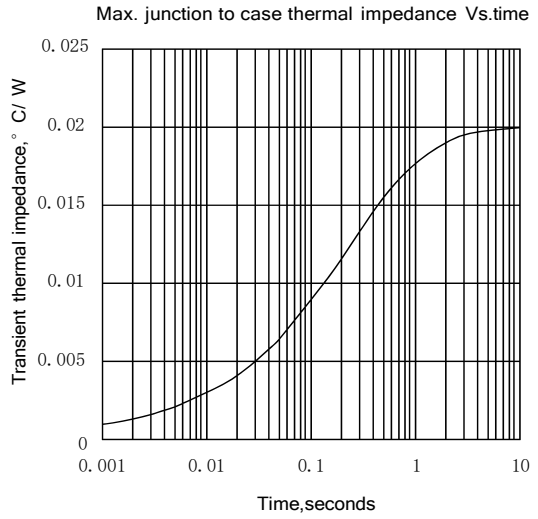

Fig. 2

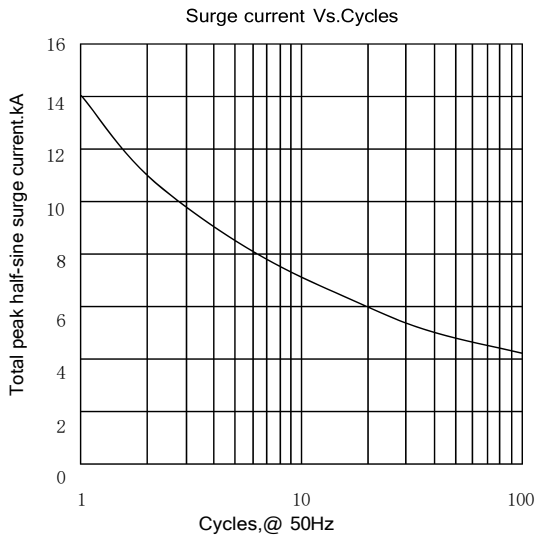

Fig. 3

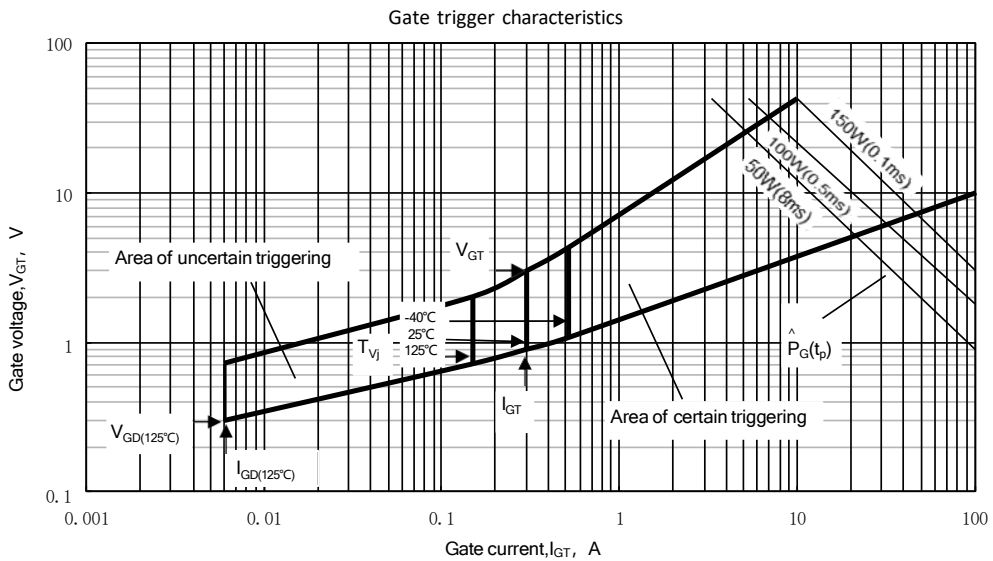
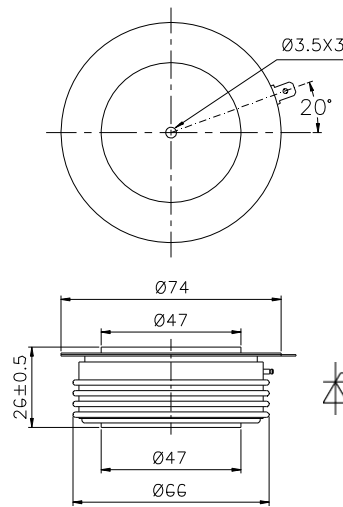

Fig. 4

Outline:

Nlps reserves the right to change specifications without notice.