

### Features

- Center amplifying gate
- Metal case with ceramic insulator
- Low on-state and switching losses

### Typical Applications

- AC controllers
- DC and AC motor control
- Controlled rectifiers

$I_{T(AV)}$	<b>1300A</b>
$V_{DRM}/V_{RRM}$	<b>200 ~ 600V</b>
$I_{TSM}$	<b>18 kA</b>
$I^2t$	<b>1620 10<sup>3</sup>A<sup>2</sup>S</b>

SYMBOL	CHARACTERISTIC	TEST CONDITIONS		T <sub>J</sub> (°C)	VALUE			UNIT
					Min	Type	Max	
$I_{T(AV)}$	Mean on-state current	180° half sine wave 50Hz Double side cooled	T <sub>c</sub> =70°C	125			1300	A
$V_{DRM}$ $V_{RRM}$	Repetitive peak off-state voltage Repetitive peak reverse voltage	tp=10ms		125	200		600	V
$I_{DRM}$ $I_{RRM}$	Repetitive peak current	at $V_{DRM}$ at $V_{RRM}$		125			40	mA
$I_{TSM}$	Surge on-state current	10ms half sine wave		125			18	kA
$I^2t$	$I^2t$ for fusing coordination	$V_R=0.6V_{RRM}$					1620	A <sup>2</sup> s*10 <sup>3</sup>
$V_{TO}$	Threshold voltage			125			0.76	V
$r_T$	On-state slope resistance						0.14	mΩ
$V_{TM}$	Peak on-state voltage	$I_{TM}=2000A, F=15kN$		25			1.34	V
dv/dt	Critical rate of rise of off-state voltage	$V_{DM}=0.67V_{DRM}$		125			1000	V/μs
di/dt	Critical rate of rise of on-state current	$V_{DM}=67\%V_{DRM}$ to 1300A, Gate pulse $t_r \leq 0.5\mu s$ $I_{GM}=1.5A$		125			100	A/μs
$Q_{rr}$	Recovery charge	$I_{TM}=1000A, tp=4000\mu s, di/dt=-20A/\mu s,$ $V_R=100V$		125		1000		μC
$I_{GT}$	Gate trigger current	$V_A=12V, I_A=1A$		25	35		300	mA
$V_{GT}$	Gate trigger voltage				0.8		2.5	V
$I_H$	Holding current				20		250	mA
$I_L$	Latching current						500	mA
$V_{GD}$	Non-trigger gate voltage	$V_{DM}=0.67V_{DRM}$		125			0.3	V
$R_{th(j-c)}$	Thermal resistance Junction to case	D.C. double side cooled Clamping force 15kN					0.035	°C/W
$R_{th(c-h)}$	Thermal resistance case to heatsink						0.008	
$F_m$	Mounting force				10		20	kN
$T_{vj}$	Junction temperature				-40		125	°C
$T_{stg}$	Stored temperature				-40		140	°C
$W_t$	Weight					150		g
Outline	P04							

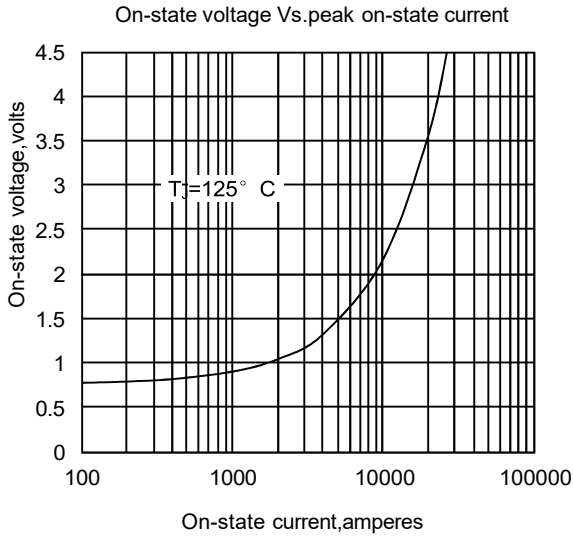

Fig1

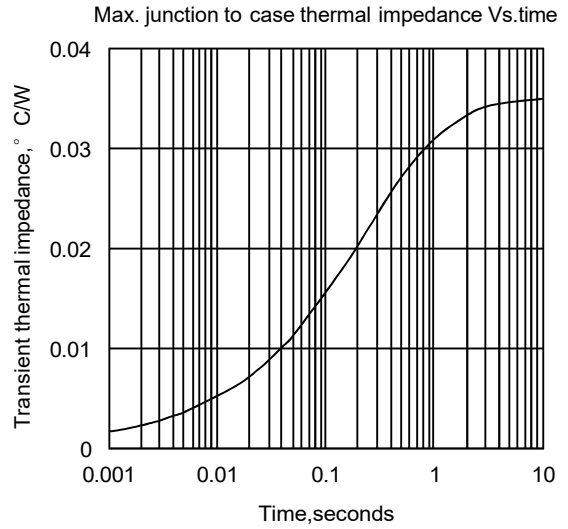

Fig2

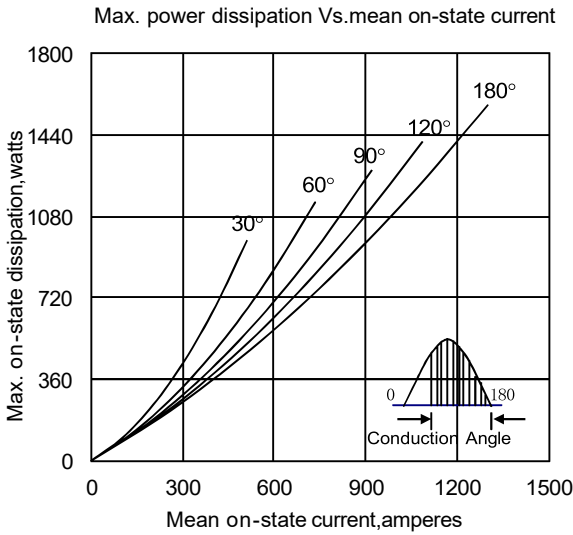

Fig3

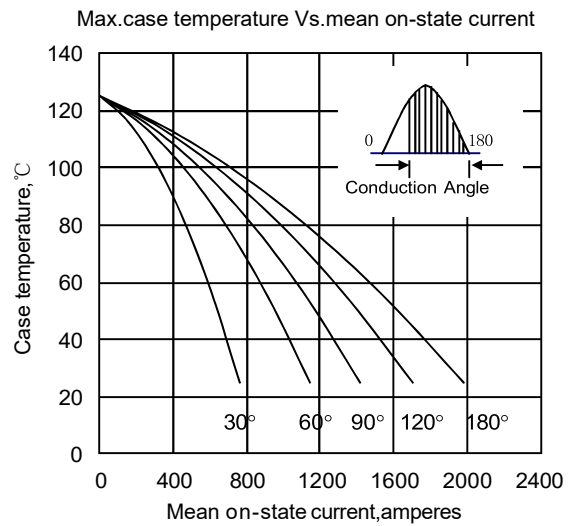

Fig4

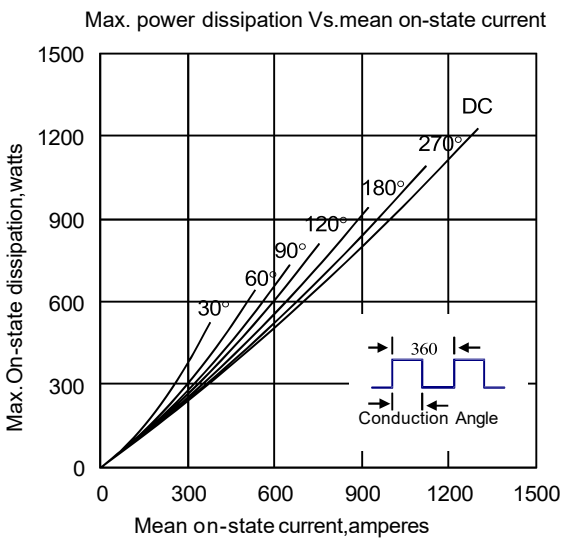

Fig5

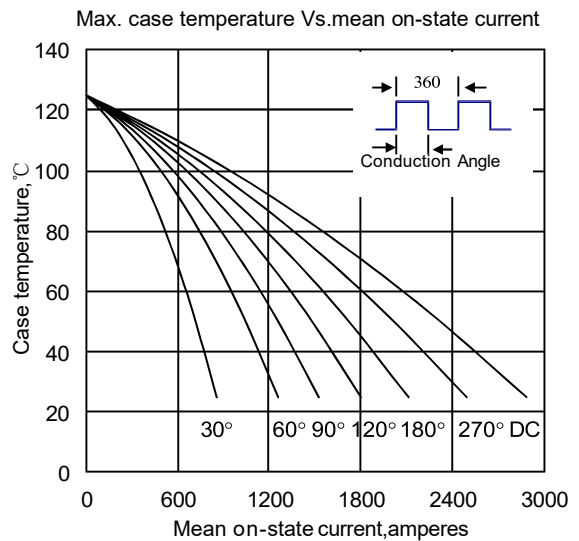

Fig6

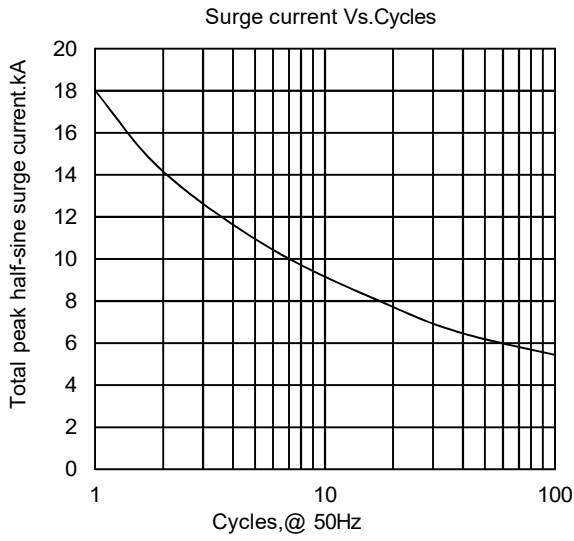

Fig7

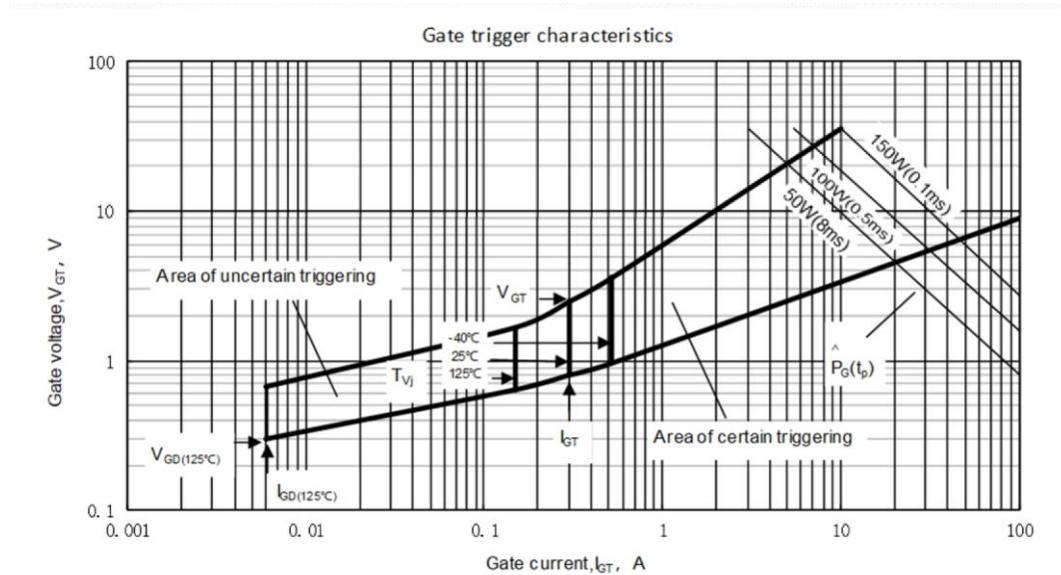
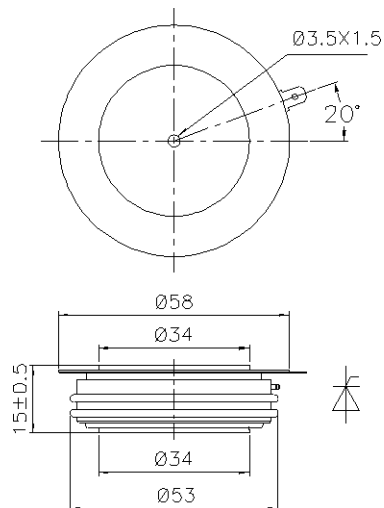

Fig8

Outline:



Nlps reserves the right to change specifications without notice.