

Features

- Interdigitated amplifying gates
- Fast turn-on and high di/dt
- Low switching losses

Typical Applications

- Inductive heating
- Electronic welders
- Self-commutated inverters

$I_{T(AV)}$	1080A
V_{DRM}/V_{RRM}	800~1800V
t_q	18~50μs
I_{TSM}	10 kA
I^2t	500 10³A²S

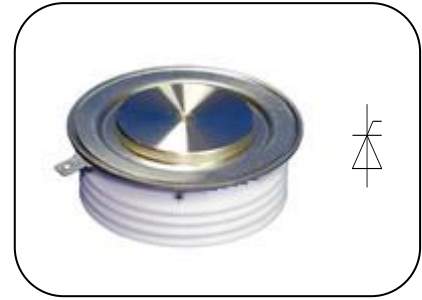

SYMBOL	CHARACTERISTIC	TEST CONDITIONS	T _i (°C)	VALUE			UNIT
				Min	Type	Max	
$I_{T(AV)}$	Mean on-state current	180° half sine wave 50Hz Double side cooled, T _c =55°C	125			1080	A
V_{DRM} V_{RRM}	Repetitive peak off-state voltage Repetitive peak reverse voltage	tp=10ms	125	800		1800	V
I_{DRM} I_{RRM}	Repetitive peak current	at V_{DRM} at V_{RRM}	125			50	mA
I_{TSM}	Surge on-state current	10ms half sine wave	125			10	kA
I^2t	I^2t for fusing coordination					500	A ² s*10 ³
V_{TO}	Threshold voltage		125			1.30	V
r_T	On-state slope resistance					0.38	mΩ
V_{TM}	Peak on-state voltage	I _{TM} =1800A, F=18kN	125			1.98	V
dv/dt	Critical rate of rise of off-state voltage	V _{DM} =0.67V _{DRM}	125			500	V/μs
di/dt	Critical rate of rise of on-state current	V _{DM} = 67%V _{DRM} to 1600A, Gate pulse t _r ≤0.5μs I _{GM} =1.5A	125			1200	A/μs
Q _{rr}	Recovery charge	I _{TM} =1000A, tp=2000μs, di/dt=-60A/μs, V _R =50V	125		550		μC
t _q	Circuit commutated turn-off time	I _{TM} =1000A, tp=2000μs, V _R =50V dv/dt=30V/μs, di/dt=-60A/μs	125	18		50	μs
I _{GT}	Gate trigger current	V _A =12V, I _A =1A	25	40		300	mA
V _{GT}	Gate trigger voltage			0.9		3.0	V
I _H	Holding current			20		400	mA
V _{GD}	Non-trigger gate voltage	V _{DM} =67%V _{DRM}	125	0.3			V
R _{th(j-c)}	Thermal resistance Junction to case	DC double side cooled Clamping force 18kN				0.0280	°C/W
R _{th(c-h)}	Thermal resistance case to heat sink					0.0075	
F _m	Mounting force			15		20	kN
T _{stg}	Stored temperature			-40		140	°C
W _t	Weight				320		g
Outline	P09						

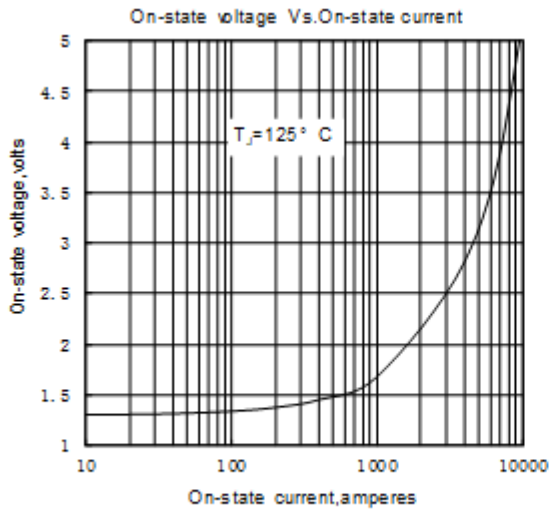

Fig. 1

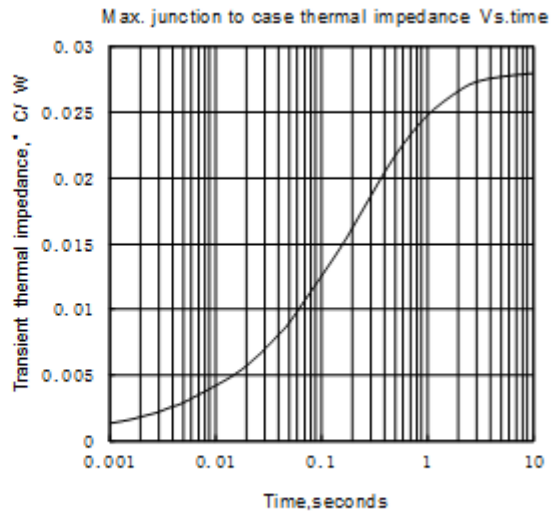

Fig. 2

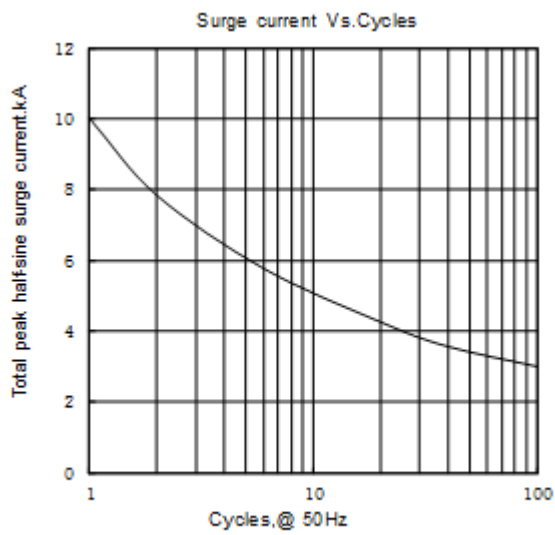

Fig. 3

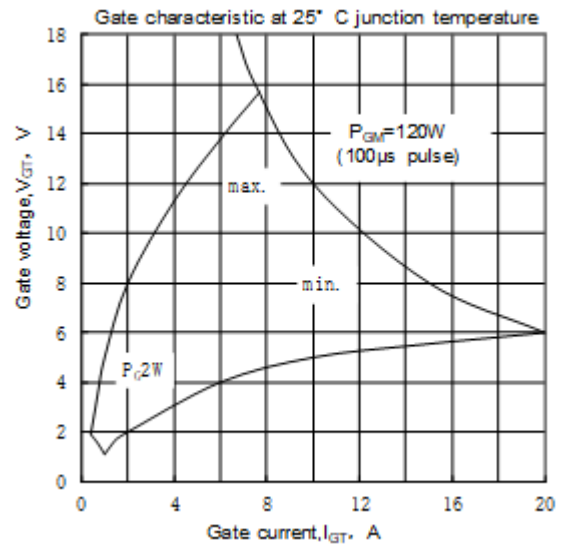

Fig. 4

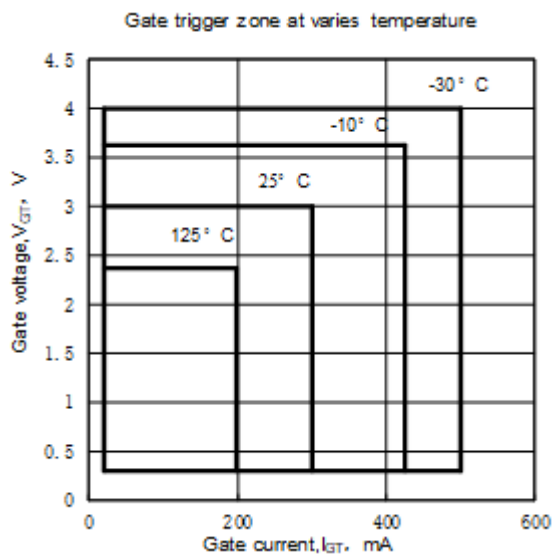
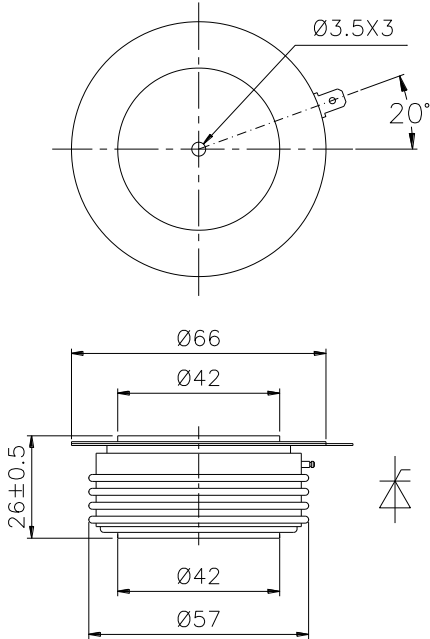

Fig. 5



Nlps reserves the right to change specifications without notice.