

Features

- Center amplifying gate
- Metal case with ceramic insulator
- Low on-state and switching losses

Typical Applications

- AC controllers
- DC and AC motor control
- Controlled rectifiers

$I_{T(AV)}$	1050A
V_{DRM}/V_{RRM}	3100 ~ 4200V
I_{TSM}	13 kA
I^2t	845 10³A²S

SYMBOL	CHARACTERISTIC	TEST CONDITIONS	$T_j(^{\circ}C)$	VALUE			UNIT
				Min	Type	Max	
$I_{T(AV)}$	Mean on-state current	180° half sine wave 50Hz Double side cooled,	$T_C=70^{\circ}C$ 125			1050	A
V_{DRM} V_{RRM}	Repetitive peak off-state voltage Repetitive peak reverse voltage	$t_p=10ms$	125	3100		4200	V
I_{DRM} I_{RRM}	Repetitive peak current	at V_{DRM} at V_{RRM}	125			100	mA
I_{TSM}	Surge on-state current	10ms half sine wave	125			13	kA
I^2t	I^2t for fusing coordination	$V_R=0.6V_{RRM}$				845	$A^2s \cdot 10^3$
V_{TO}	Threshold voltage		125			1.14	V
r_T	On-state slope resistance					0.57	mΩ
V_{TM}	Peak on-state voltage	$I_{TM}=1500A, F=24kHz$	25			2.50	V
dv/dt	Critical rate of rise of off-state voltage	$V_{DM}=0.67V_{DRM}$	125			1000	V/μs
di/dt	Critical rate of rise of on-state current	$V_{DM}=67\%V_{DRM}$ to 1300A, Gate pulse $t_r \leq 0.5\mu s$ $I_{GM}=1.5A$	125			150	A/μs
Q_{rr}	Recovery charge	$I_{TM}=1000A, t_p=4000\mu s, di/dt=-20A/\mu s,$ $V_R=100V$	125		1800		μC
I_{GT}	Gate trigger current	$V_A=12V, I_A=1A$	25	40		300	mA
V_{GT}	Gate trigger voltage			0.8		3.0	V
I_H	Holding current			20		300	mA
I_L	Latching current					1000	mA
V_{GD}	Non-trigger gate voltage	$V_{DM}=67\%V_{DRM}$	125			0.3	V
$R_{th(j-c)}$	Thermal resistance Junction to case	D.C. double side cooled Clamping force 24kN				0.020	$^{\circ}C/W$
$R_{th(c-h)}$	Thermal resistance case to heatsink					0.005	
F_m	Mounting force			19		26	kN
T_{vj}	Junction temperature			-40		125	$^{\circ}C$
T_{stg}	Stored temperature			-40		140	$^{\circ}C$
W_t	Weight				440		g
Outline	P11						

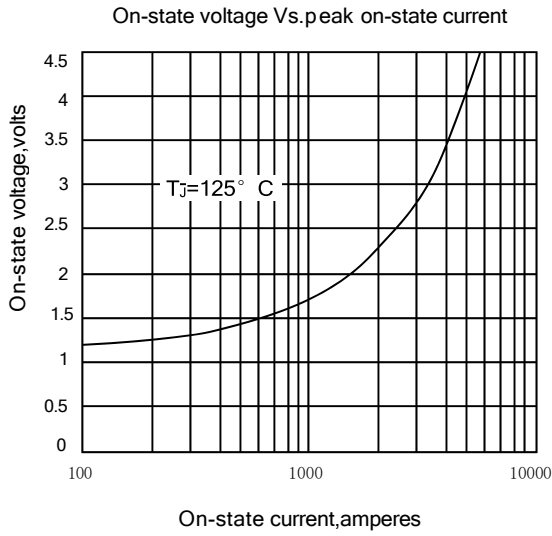

Fig1

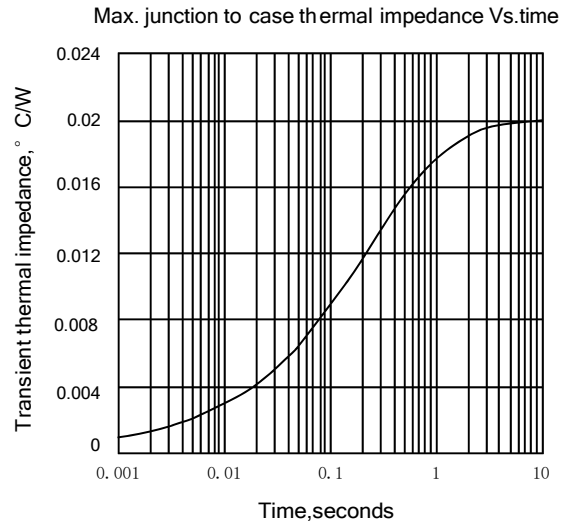

Fig2

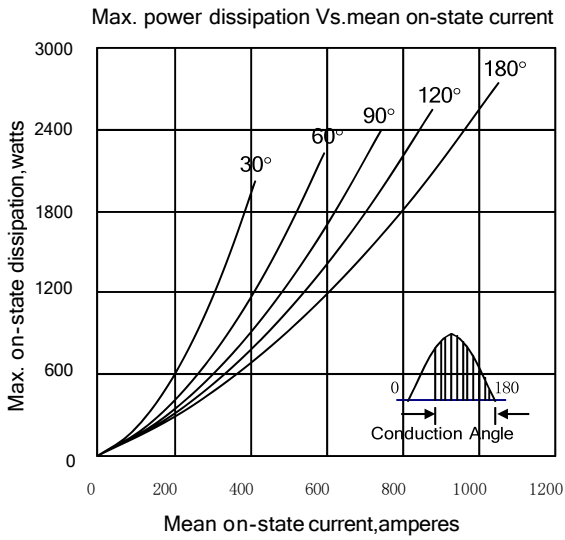

Fig3

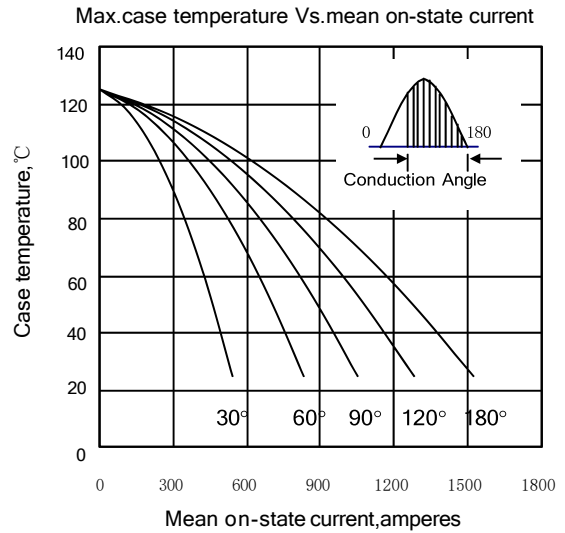

Fig4

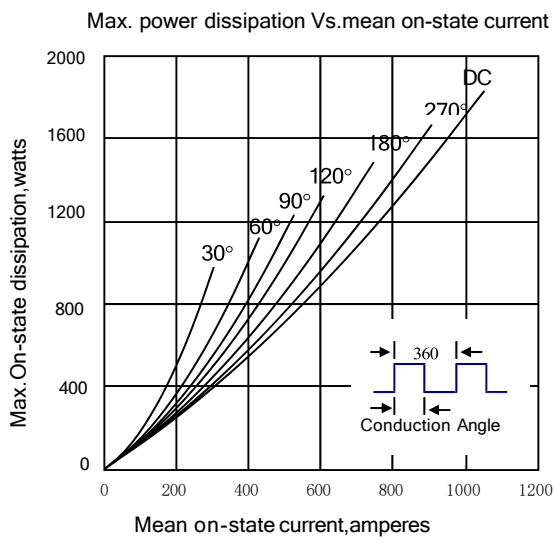

Fig5

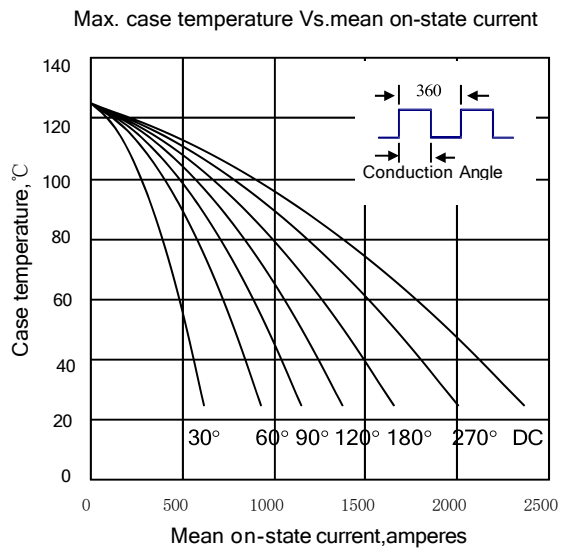

Fig6

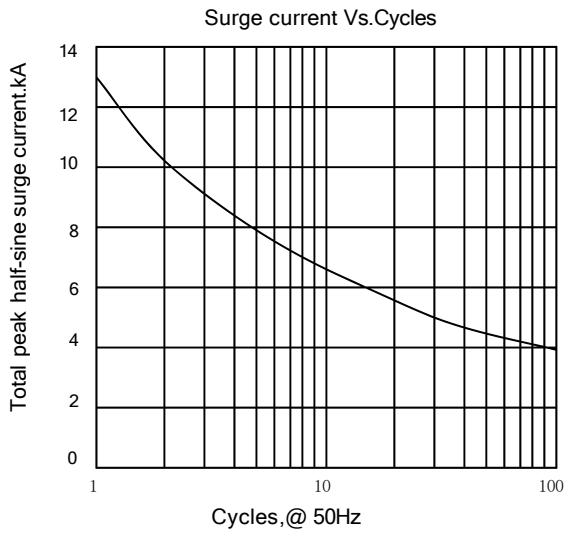

Fig7

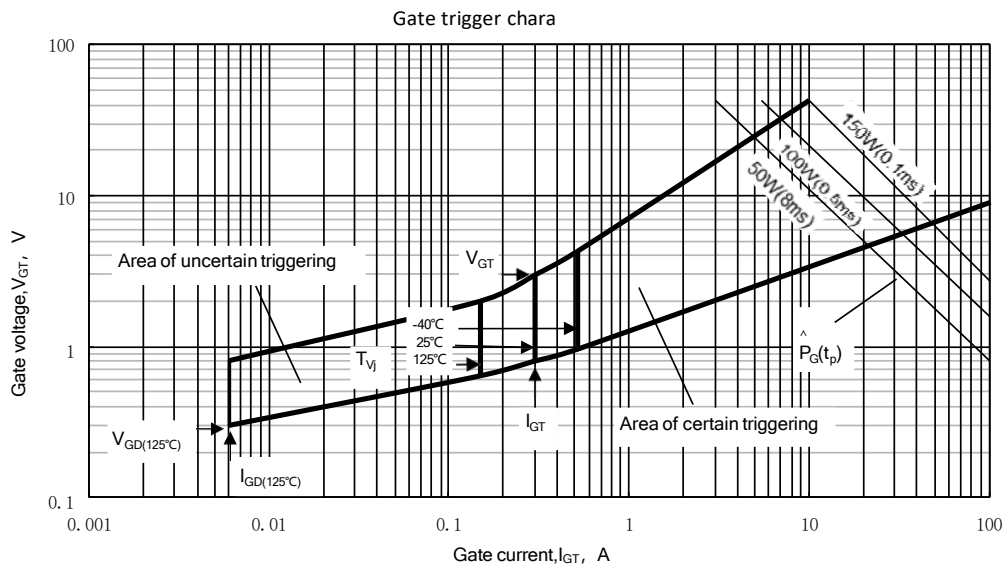
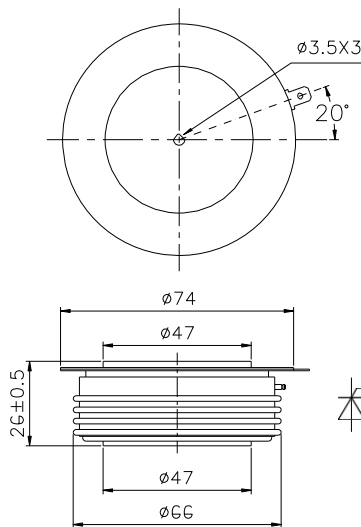

Fig. 8

Outline:



Nlps reserves the right to change specifications without notice.