

Features

- Optimized for high current rectifiers
- Very low threshold voltage and slop resistance
- Very low thermal resistance

$I_{F(AV)}$ 10000 A
 V_{RRM} 200~400 V
 I_{FSM} 70 kA
 I^2t 23000 10³A²S

Typical Applications

- High current application For Welders up to 5000Hz
- Electrode plating

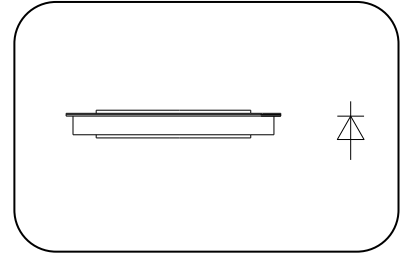

SYMBOL	CHARACTERISTIC	TEST CONDITIONS	T _i (°C)	VALUE			UNIT
				Min	Type	Max	
$I_{F(AV)}$	Mean forward current	180° half sine wave 50Hz Double side cooled, T _c =100°C	175			10000	A
V_{RRM}	Repetitive peak reverse voltage	t _p =10ms	175	200		400	V
I_{RRM}	Repetitive peak current	at V _{RRM}	175			50	mA
I_{FSM}	Surge forward current	10ms half sine wave	175			70	kA
I^2t	I ² t for fusing coordination	V _R =0V _{RRM}				23000	10 ³ A ² s
V_{FO}	Threshold voltage	I _{FM} =10000-30000A	175			0.79	V
r _F	Forward slope resistance						0.026
V_{FM}	Max Peak on-state voltage	I _{FM} =6000A, F=50kN	25			1.00	V
I _{rr}	Recovery current	I _{FM} =1000A, t _p =2000μs, di/dt=-20A/μs, V _R =50V	175			60	A
t _{rr}	Recovery time					5.0	μs
Q _{rr}	Recovery charge					200	μC
R _{th(j-c)}	Thermal resistance Junction to case	DC double side cooled Clamping force 50.0kN				0.006	°C /W
R _{th(c-h)}	Thermal resistance case to heat sink					0.003	
F _m	Mounting force			35	50	65	kN
T _{stg}	Stored temperature			-40		175	°C
W _t	Weight				220		g
Outline	P59						

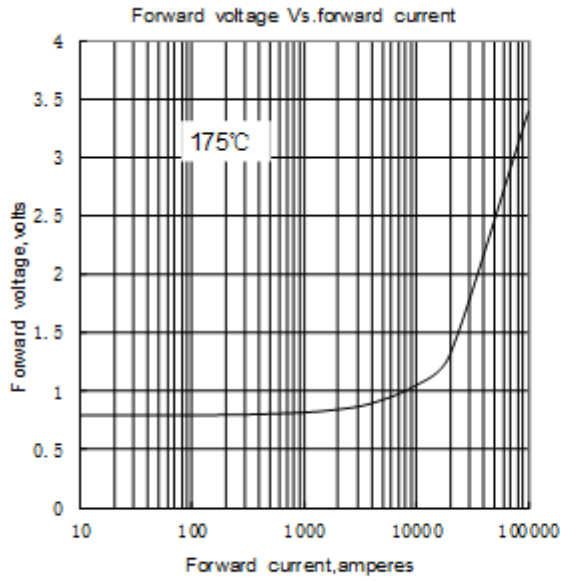

Fig.1

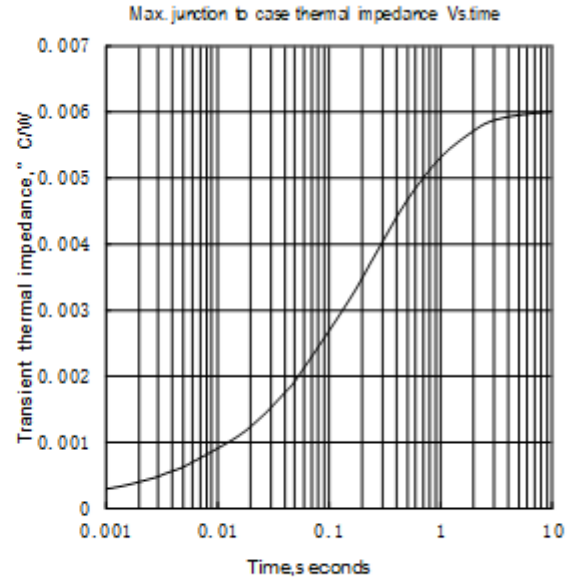

Fig.2

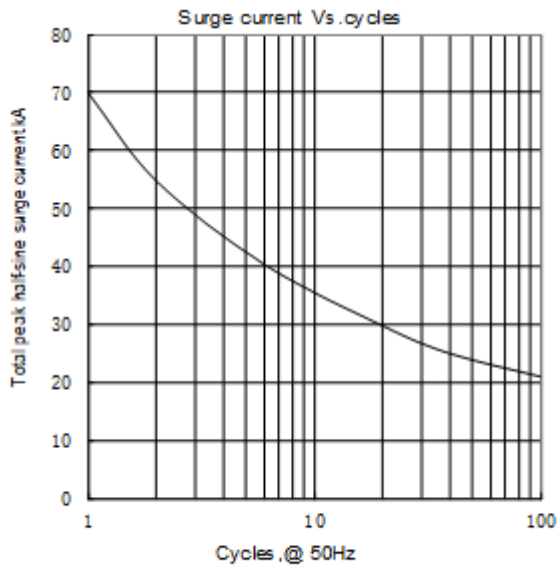
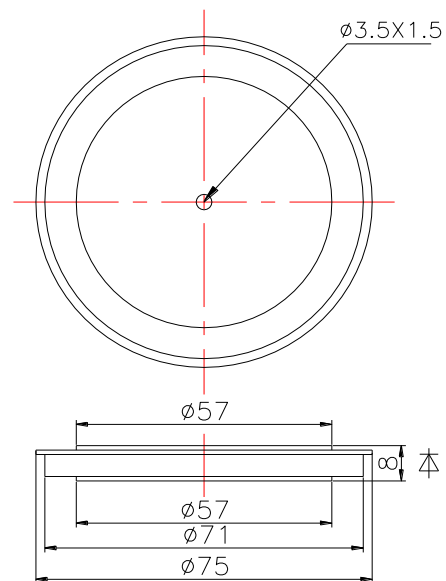

Fig.3



Nlps reserves the right to change specifications without notice.