

**Features :**

- Isolated mounting base 3000V~
- Pressure contact technology with Increased power cycling capability
- Space and weight saving

**Typical Applications :**

- Various rectifiers
- DC supply for PWM inverter

V <sub>RSM</sub>	V <sub>RRM</sub>	品名
2100V	2000V	Mx160D200
2300V	2200V	Mx160D220
2600V	2500V	Mx160D250

SYMBOL	CHARACTERISTIC	TEST CONDITIONS	T <sub>J</sub> (°C)	VALUE			UNIT
				Min	Type	Max	
I <sub>F(AV)</sub>	Mean forward current	180° half sine wave 50Hz Single side cooled, T <sub>C</sub> =100°C	150			160	A
I <sub>F(RMS)</sub>	RMS forward current					251	A
I <sub>RRM</sub>	Repetitive peak current	at V <sub>RRM</sub>	150			12	mA
I <sub>FSM</sub>	Surge forward current	V <sub>R</sub> =60%V <sub>RRM</sub> , t=10ms half sine	150			4.6	kA
I <sup>2</sup> t	I <sup>2</sup> t for fusing coordination					105	10 <sup>3</sup> A <sup>2</sup> s
V <sub>FO</sub>	Threshold voltage		150			0.85	V
r <sub>F</sub>	Forward slope resistance					1.31	mΩ
V <sub>FM</sub>	Peak forward voltage	I <sub>FM</sub> =480A	25			1.47	V
R <sub>th(j-c)</sub>	Thermal resistance Junction to case	D.C. Single side cooled per chip				0.23	°C/W
R <sub>th(c-h)</sub>	Thermal resistance case to heatsink	D.C. Single side cooled per chip				0.08	°C/W
V <sub>iso</sub>	Isolation voltage	50Hz,R.M.S,t=1min,I <sub>iso</sub> :1mA(MAX)		3000			V
F <sub>m</sub>	Terminal connection torque(M6)			4.5		6.0	N·m
	Mounting torque(M6)			4.5		6.0	N·m
T <sub>vj</sub>	Junction temperature			-40		150	°C
T <sub>stg</sub>	Stored temperature			-40		125	°C
W <sub>t</sub>	Weight				320		g
Outline	M02						

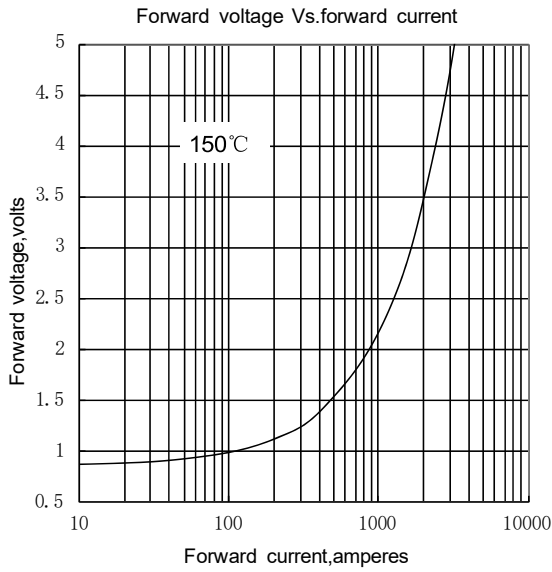

Fig.1

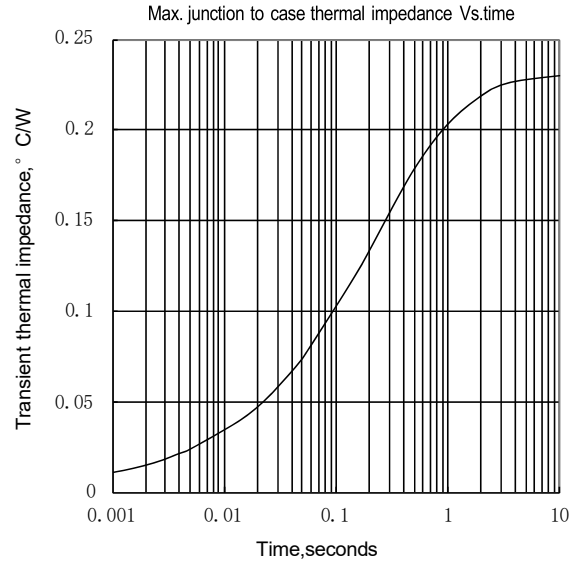

Fig.2

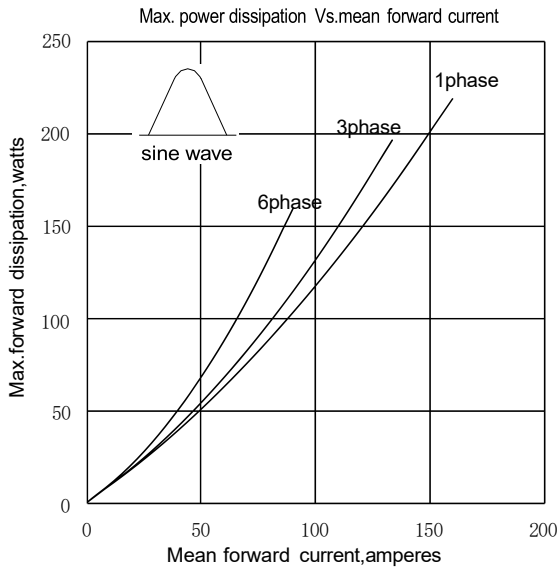

Fig.3

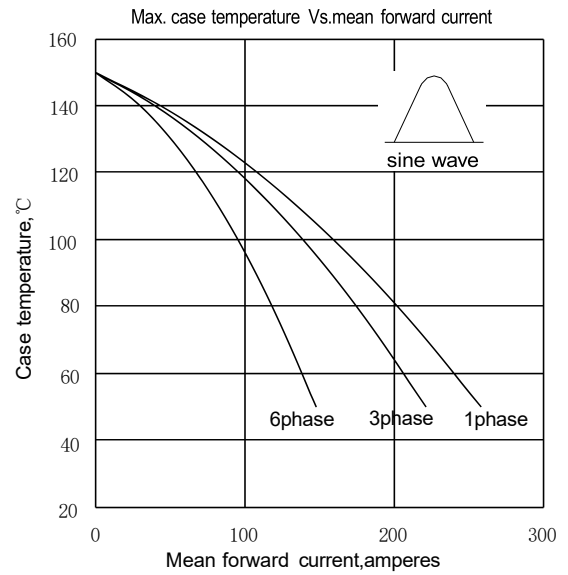

Fig.4

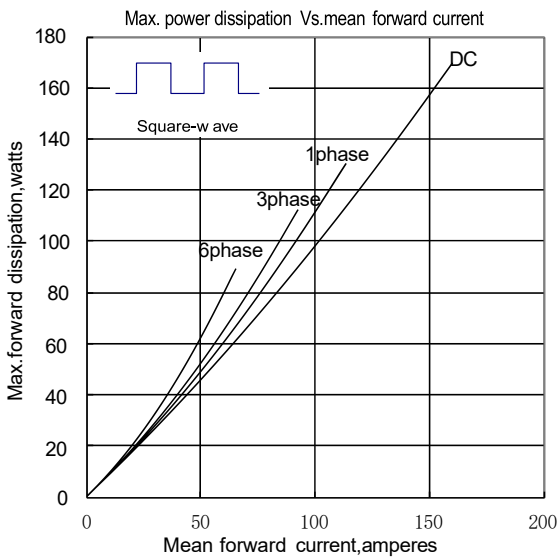

Fig.5

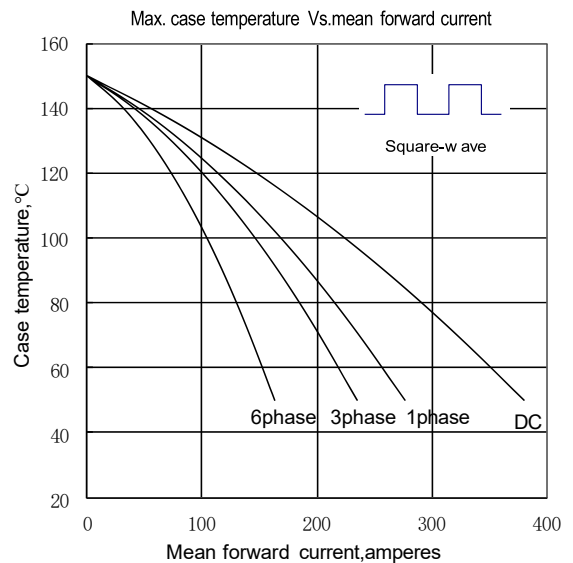

Fig.6

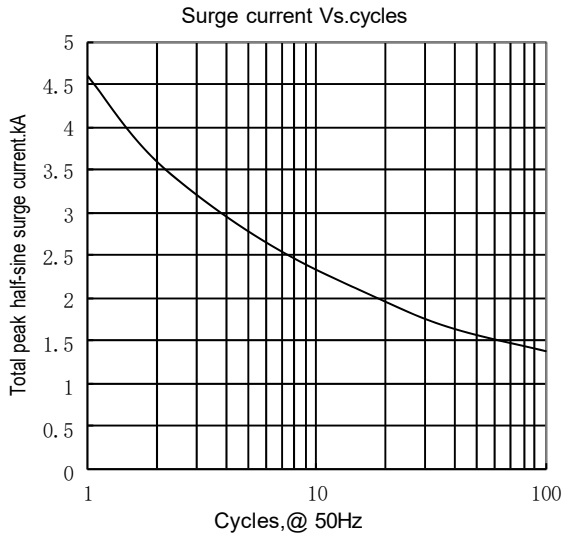
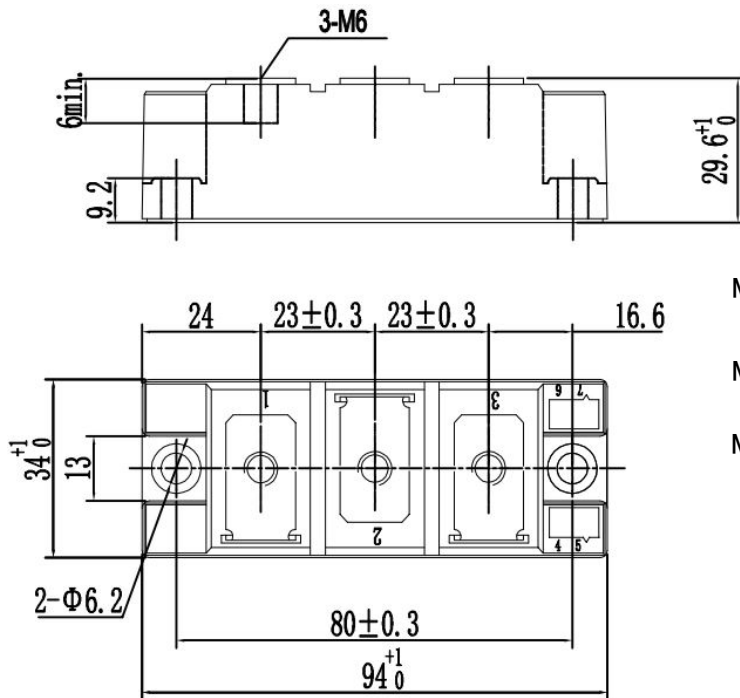

Fig.7

**Outline:**



Unmarked dimensional tolerance: ±0.5mm

