

Features :

- Isolated mounting base 3000V~
- Pressure contact technology with Increased power cycling capability
- Space and weight saving

Typical Applications :

- Various rectifiers
- DC supply for PWM inverter

| V _{RSM} | V _{RRM} | 品名 |
|------------------|------------------|-----------|
| 700V | 600V | Mx160D60 |
| 900V | 800V | Mx160D80 |
| 1100V | 1000V | Mx160D100 |
| 1300V | 1200V | Mx160D120 |
| 1500V | 1400V | Mx160D140 |
| 1700V | 1600V | Mx160D160 |
| 1900V | 1800V | Mx160D180 |

| SYMBOL | CHARACTERISTIC | TEST CONDITIONS | T _J (°C) | VALUE | | | UNIT |
|----------------------|--|---|---------------------|-------|------|------|----------------------------------|
| | | | | Min | Type | Max | |
| I _{F(AV)} | Mean forward current | 180° half sine wave 50Hz Single side cooled, T _C =100°C | 150 | | | 160 | A |
| I _{F(RMS)} | RMS forward current | | | | | 251 | A |
| I _{RRM} | Repetitive peak current | at V _{RRM} | 150 | | | 12 | mA |
| I _{FSM} | Surge forward current | V _R =60%V _{RRM} ,t=10ms half sine, | 150 | | | 4.60 | kA |
| I ² t | I ² t for fusing coordination | | | | | 106 | 10 ³ A ² s |
| V _{FO} | Threshold voltage | | 150 | | | 0.80 | V |
| r _F | Forward slope resistance | | | | | 1.35 | mΩ |
| V _{FM} | Peak forward voltage | I _{FM} =480A | 25 | | | 1.45 | V |
| R _{th(j-c)} | Thermal resistance Junction to case | D.C. Single side cooled per chip | | | | 0.23 | °C/W |
| R _{th(c-h)} | Thermal resistance case to heatsink | D.C. Single side cooled per chip | | | | 0.08 | °C/W |
| V _{iso} | Isolation voltage | 50Hz,R.M.S,t=1min,I _{iso} :1mA(MAX) | | 3000 | | | V |
| F _m | Terminal connection torque(M6) | | | 4.5 | | 6.0 | N·m |
| | Mounting torque(M6) | | | 4.5 | | 6.0 | N·m |
| T _{vj} | Junction temperature | | | -40 | | 150 | °C |
| T _{stg} | Stored temperature | | | -40 | | 125 | °C |
| W _t | Weight | | | | 320 | | g |
| Outline | M02 | | | | | | |

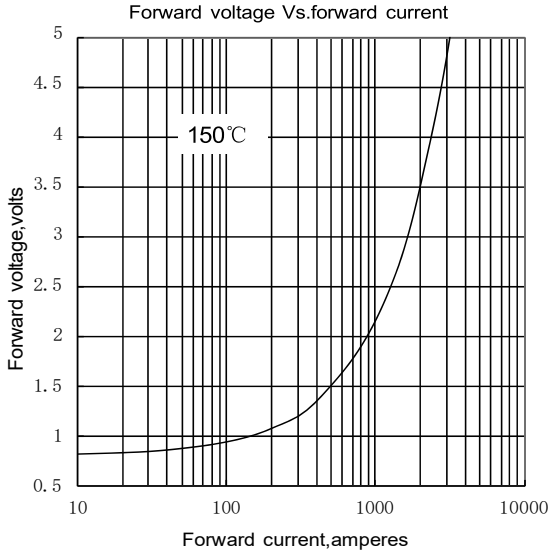

Fig.1

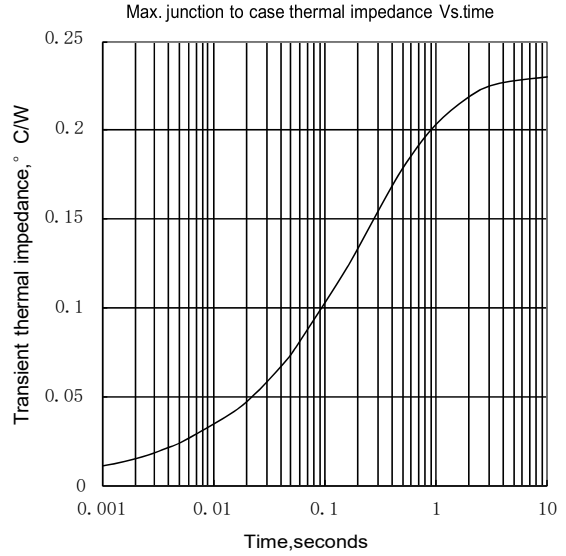

Fig.2

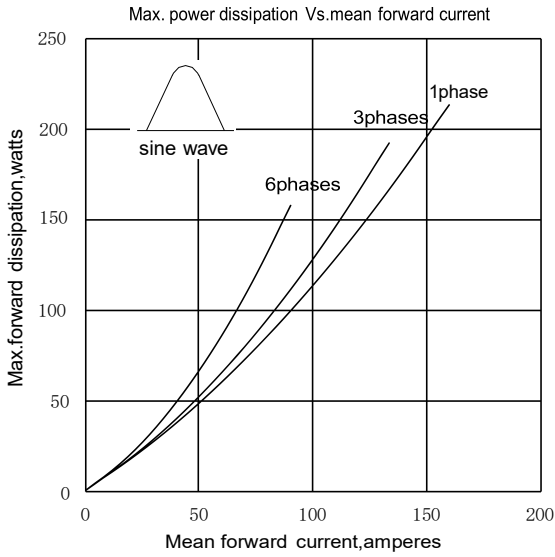

Fig.3

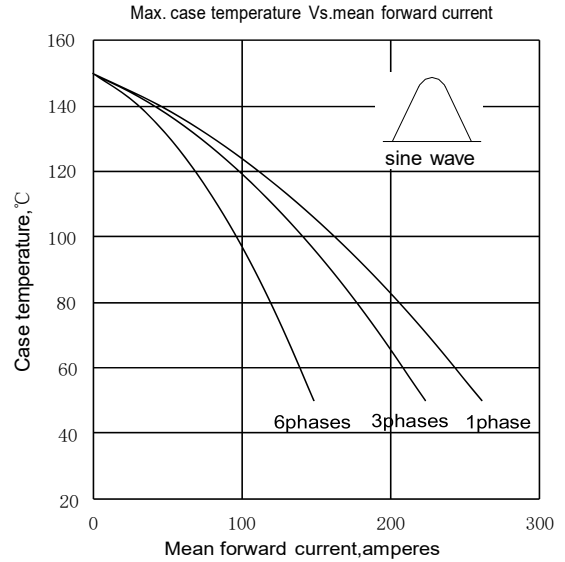

Fig.4

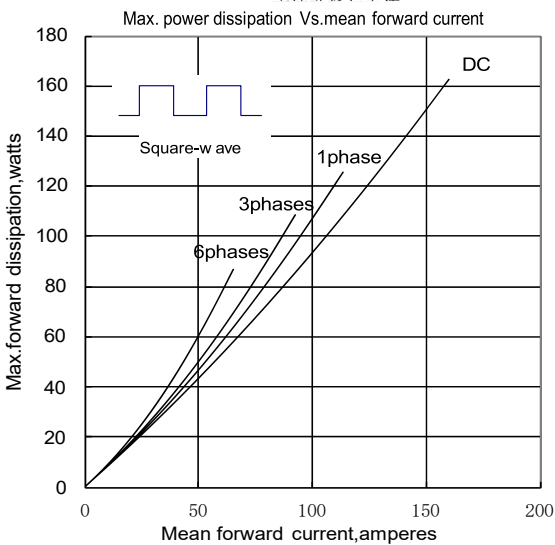

Fig.5

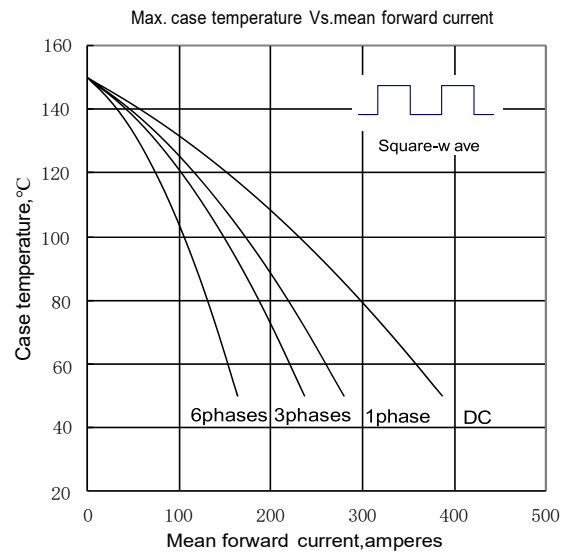

Fig.6

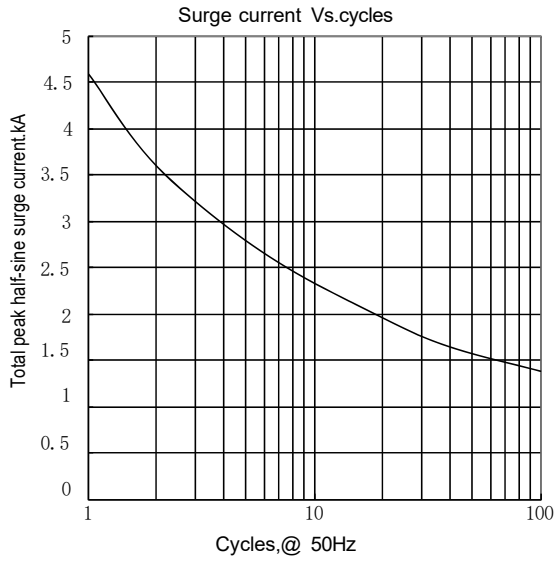
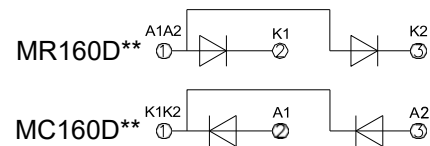
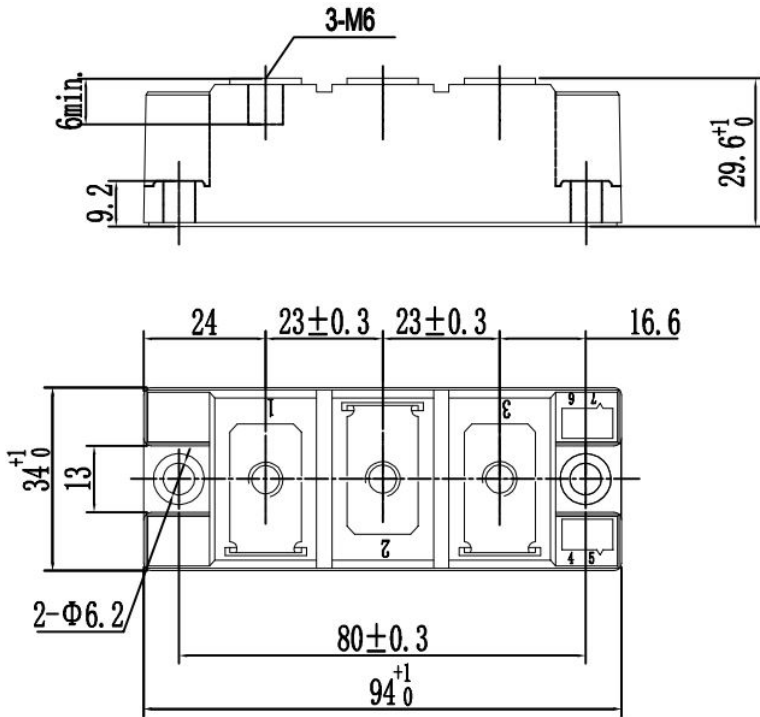

Fig.7

Outline:



Unmarked dimensional tolerance: $\pm 0.5\text{mm}$