

Features :

- 10µs short circuit capability
- $V_{CE(sat)}$ with positive temperature coefficient
- Low $V_{CE(sat)}$ trench IGBT technology
- Fast & soft reverse recovery anti-parallel FWD
- Isolated copper baseplate using DBC technology

Typical Applications :

- Inverter for motor drive
- AC and DC servo drive amplifier
- Uninterruptible power supply

SYMBOL	CHARACTERISTIC	TEST CONDITIONS	VALUE			UNIT
			Min	Type	Max	
V_{CES}	Collector-Emitter voltage	$T_j=25^{\circ}C$			1700	V
V_{GES}	Gate-Emitter voltage	$T_j=25^{\circ}C$			± 20	V
I_C	Collector current	$T_c=100^{\circ}C$			450	A
I_{CM}	Repetitive peak collector current	$t_p=1ms$			900	A
P_C	Maximum Power Dissipation	$T_j=175^{\circ}C$			2542	W
T_{jmax}	Junction temperature	/			175	$^{\circ}C$
T_{jop}	Operating junction temperature		-40		150	$^{\circ}C$
T_{stg}	Storage temperature	/	-40		125	$^{\circ}C$
V_{iso}	Isolation between terminal and copper base	$T_j=25^{\circ}C, AC: 1minute$	4000			V
I_{CES}	Zero gate voltage collector current	$T_j=25^{\circ}C, V_{CE}=1700V, V_{GE}=0V$			5	mA
I_{GES}	Gate-Emitter leakage current	$T_j=25^{\circ}C, V_{CE}=0V, V_{GE}=\pm 20V$			0.4	μA
$V_{GE(th)}$	Gate-Emitter threshold voltage	$T_j=25^{\circ}C, V_{CE}=20V, I_C=18mA$	5.6	6.2	6.8	V
$V_{CE(sat)}$	Collector-Emitter saturation voltage	$T_j=25^{\circ}C, V_{GE}=15V, I_C=450A$		1.85	2.2	V
		$T_j=125^{\circ}C, V_{GE}=15V, I_C=450A$		2.25		V
		$T_j=150^{\circ}C, V_{GE}=15V, I_C=450A$		2.35		V
R_{Gint}	Integrated gate resistor			1.67		Ω

$t_{(d)on}$	Turn-on time	$V_{CC}=900V, I_C=450A, V_{GE}=\pm 15V,$ $R_g=3.3\Omega, \text{ Inductive load}$	$T_j=25^\circ C$	179		ns
			$T_j=125^\circ C$	208		ns
			$T_j=150^\circ C$	208		ns
t_r			$T_j=25^\circ C$	105		ns
			$T_j=125^\circ C$	120		ns
			$T_j=150^\circ C$	120		ns
$t_{(d)off}$	Turn-off time		$T_j=25^\circ C$	680		ns
			$T_j=125^\circ C$	784		ns
			$T_j=150^\circ C$	800		ns
t_r			$T_j=25^\circ C$	375		ns
			$T_j=125^\circ C$	613		ns
			$T_j=150^\circ C$	720		ns
E_{on}	Turn-on switching loss	$T_j=25^\circ C$	116		mJ	
		$T_j=125^\circ C$	152		mJ	
		$T_j=150^\circ C$	167		mJ	
E_{off}	Turn-off switching loss	$T_j=25^\circ C$	113		mJ	
		$T_j=125^\circ C$	171		mJ	
		$T_j=150^\circ C$	179		mJ	
I_{sc}	SC data	$V_{GE}=15V, V_{CC}=1000V, T_j=150^\circ C,$ $V_{CEM} \leq 1700V$		1800		A
V_F	Forward on voltage	$T_j=25^\circ C, I_F=450A$		1.8	2.25	V
		$T_j=125^\circ C, I_F=450A$		1.95		V
		$T_j=150^\circ C, I_F=450A$		1.90		V
Q_r	Recovered charge	$T_j=25^\circ C$		105		μC
		$T_j=125^\circ C$		187		μC
		$T_j=150^\circ C$		209		μC
I_{RM}	Peak reverse recovery current	$T_j=25^\circ C$		198		A
		$T_j=125^\circ C$		578		A
		$T_j=150^\circ C$		585		A
E_{rec}	Reverse recovery energy	$T_j=25^\circ C$		69		mJ
		$T_j=125^\circ C$		129		mJ
		$T_j=150^\circ C$		150		mJ
R_{25}	Rated resistance			5.0		k Ω
$\Delta R/R$	Deviation of R_{100}	$T_C=100^\circ C, R_{100}=493.3\Omega$	-5		5	%
P_{25}	Power dissipation				20	mW
$B_{25/50}$	B-value	$R_2=R_{25}\exp[B_{25/50}(1/T_2-1/(298.15K))]$		3375		K
$B_{25/80}$	B-value	$R_2=R_{25}\exp[B_{25/80}(1/T_2-1/(298.15K))]$		3411		K
$B_{25/100}$	B-value	$R_2=R_{25}\exp[B_{25/100}(1/T_2-1/(298.15K))]$		3433		K
L_{CE}	Stray inductance			20		nH
R_{CC+EE}	Module lead resistance, terminal to chip			1.10		m Ω
$R_{th(j-c)}$	Thermal resistance(per chip)	IGBT		0.059		$^\circ C/W$
		FWD		0.083		$^\circ C/W$
W_t	Weight				350	g
Outline	M43					

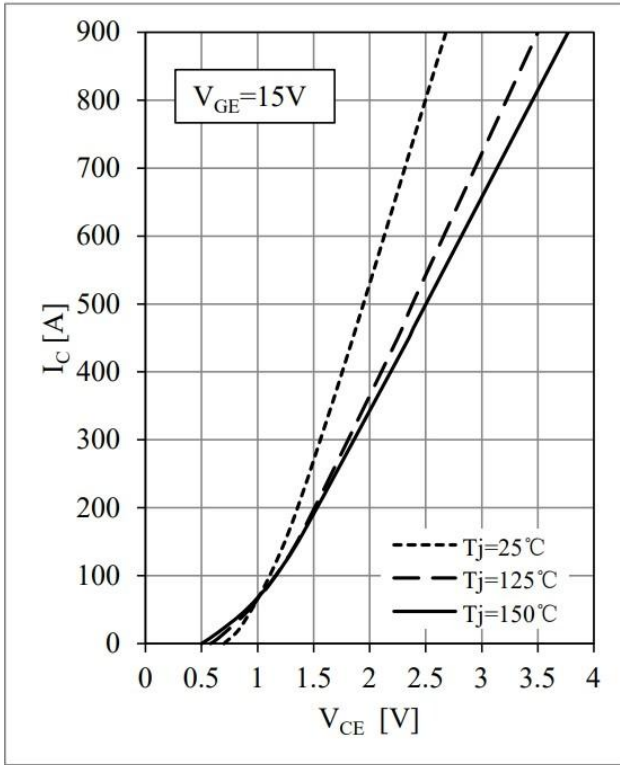

Fig 1. IGBT Output Characteristics

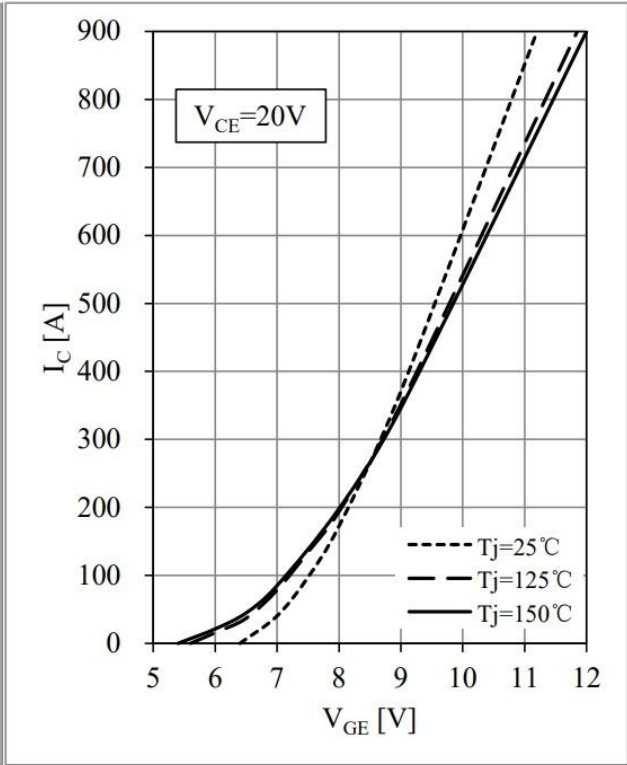

Fig 2. IGBT Transfer Characteristics

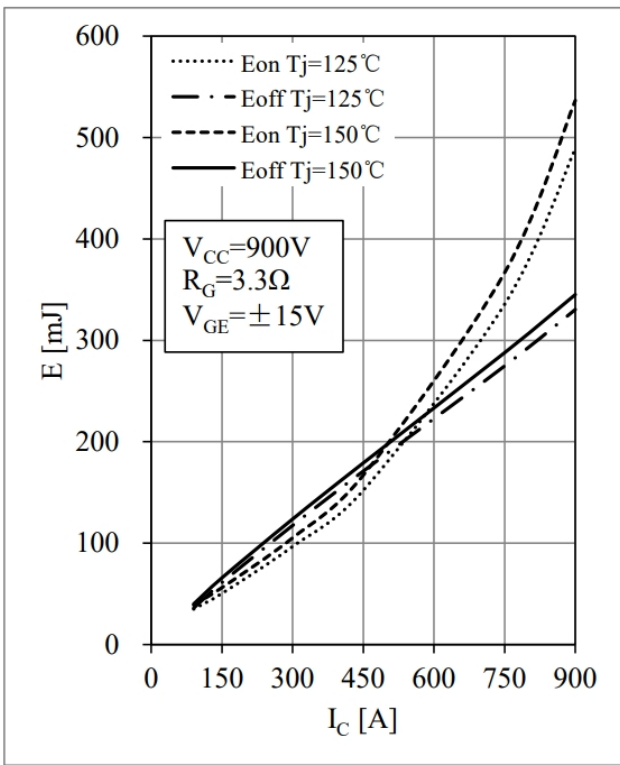

Fig 3. IGBT Switching Loss vs. I_C

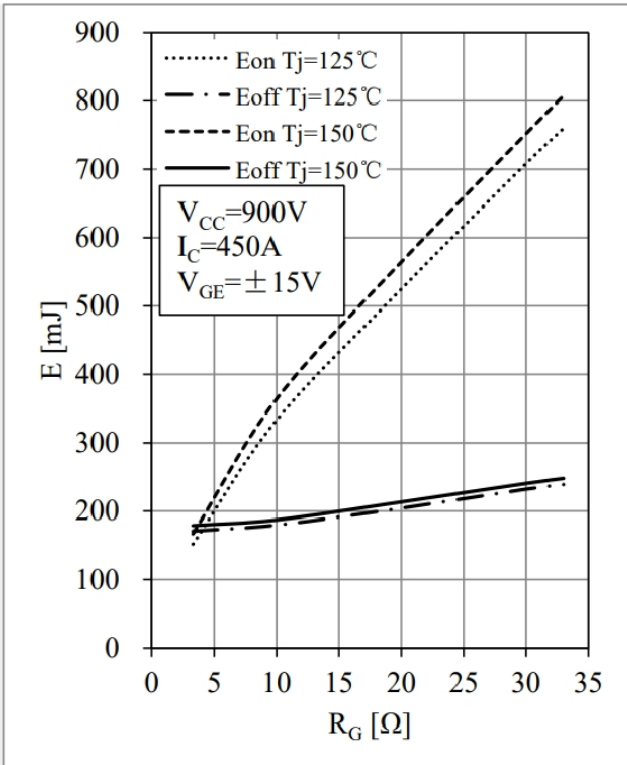

Fig 4. IGBT Switching Loss vs. R_G

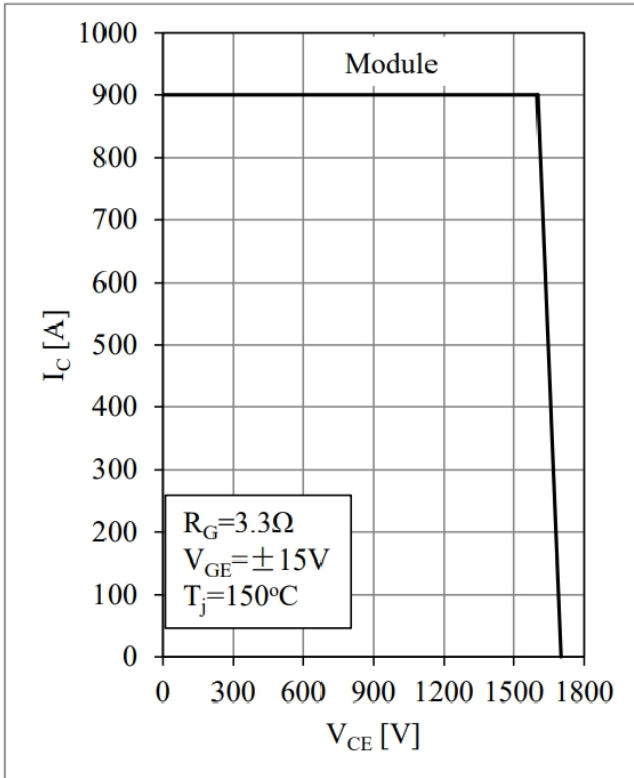

Fig 5. RBSOA

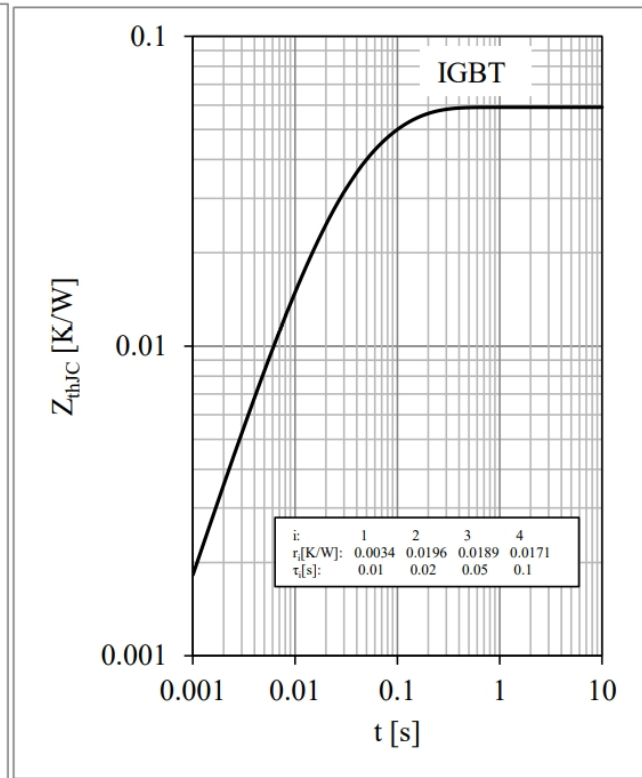

Fig 6. IGBT Transient Thermal Impedance

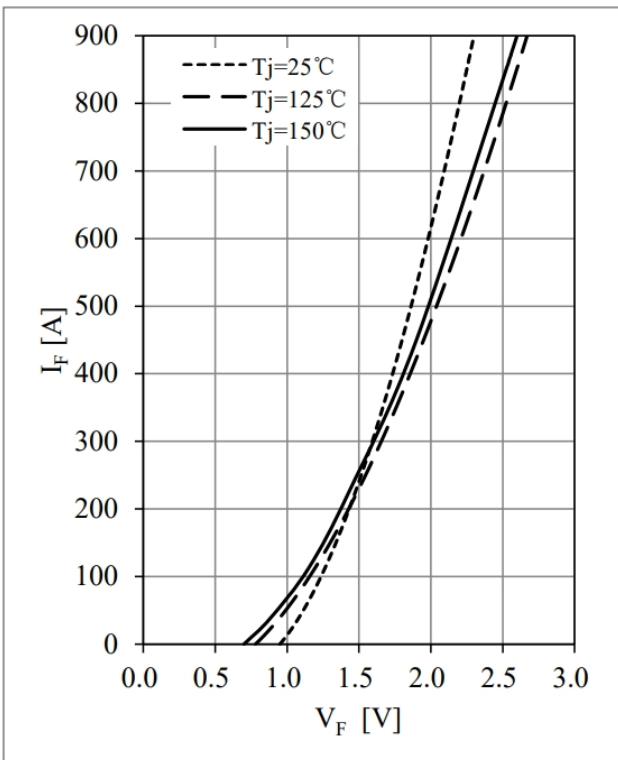

Fig 7. Diode Forward Characteristics

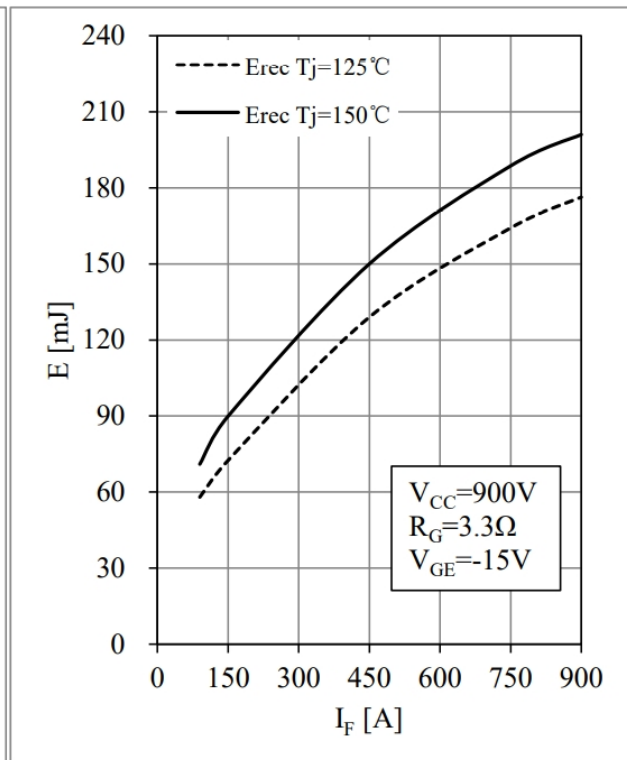

Fig 8. Diode Switching Loss vs. I_F

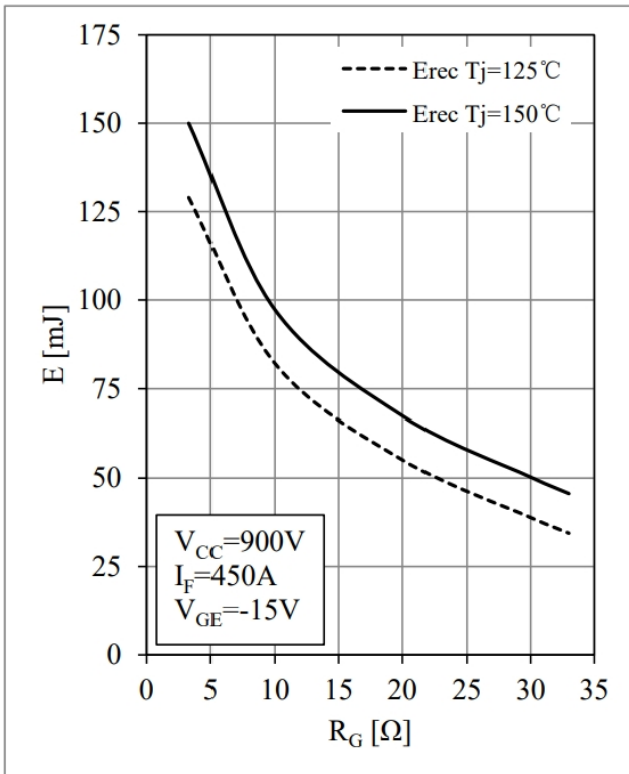

Fig 9. Diode Switching Loss vs. R_G

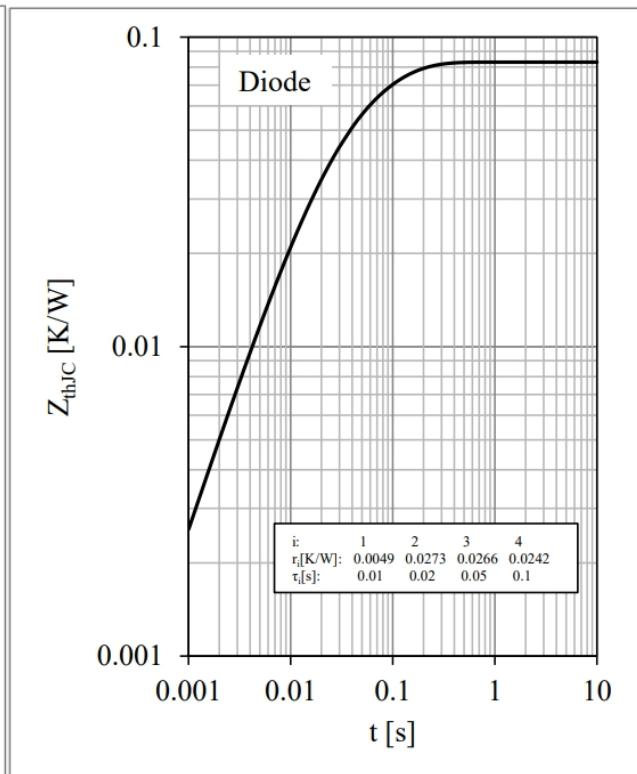

Fig 10. Diode Transient Thermal Impedance

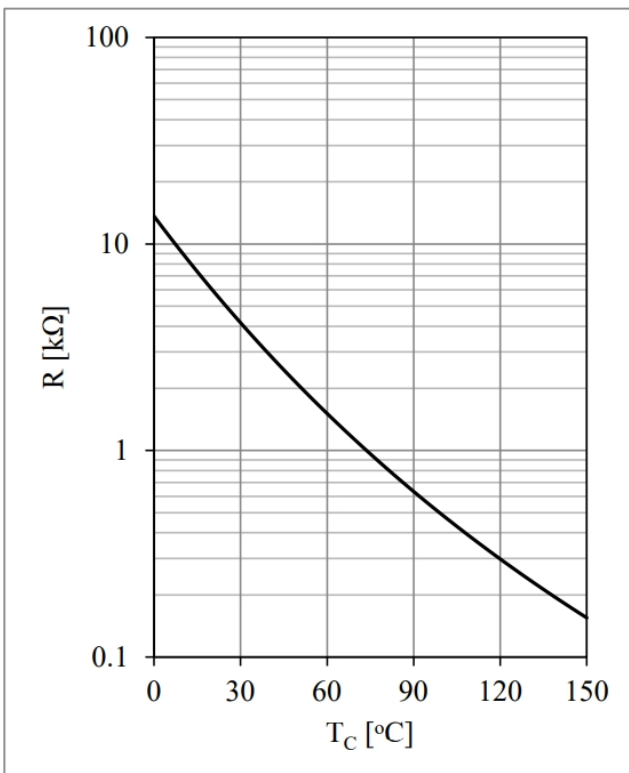
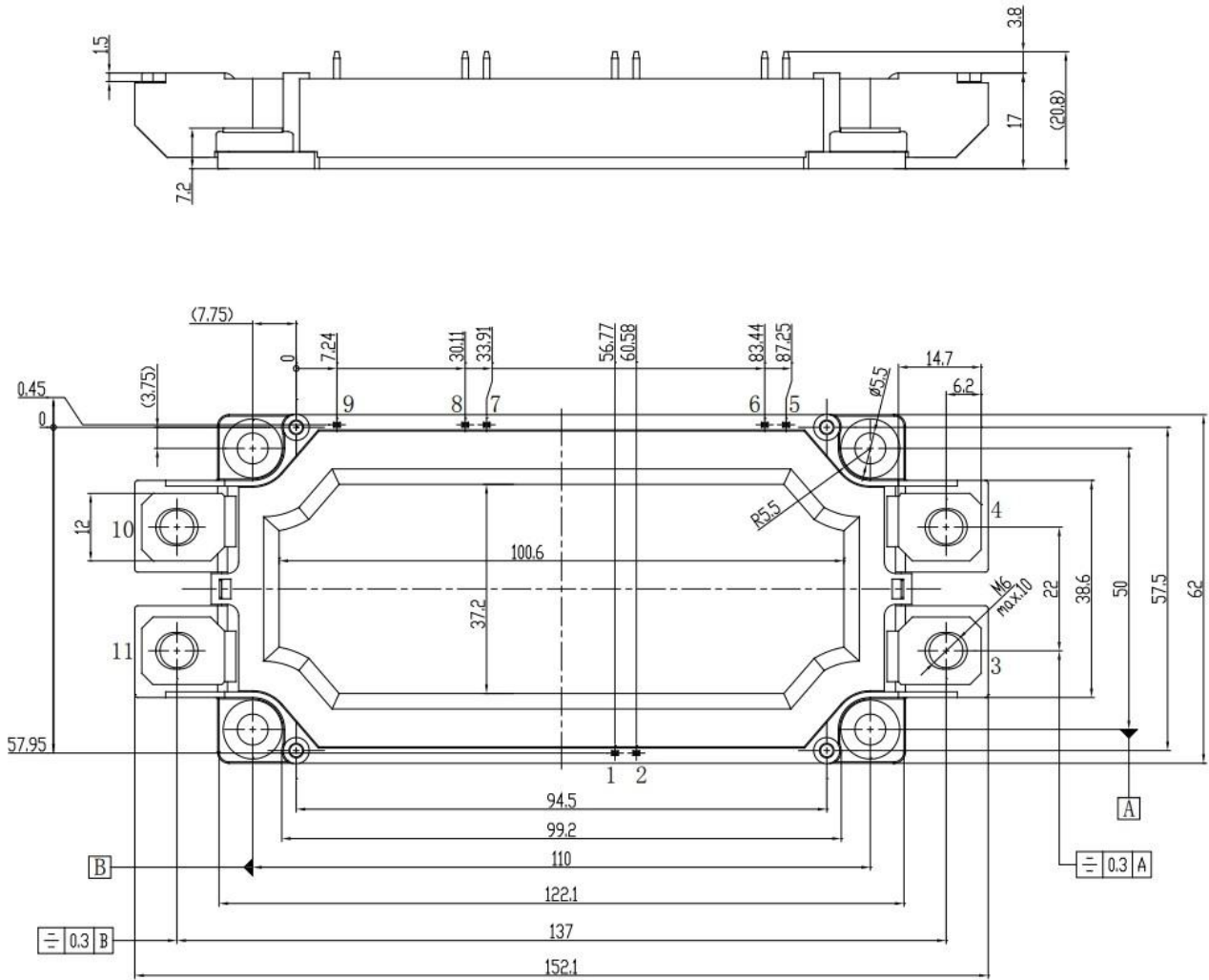
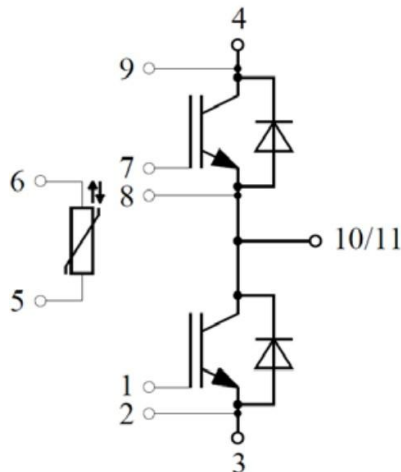

Fig 11. NTC Temperature Characteristic

Outline:



MD450MB170S



Unmarked dimensional tolerance: $\pm 0.5\text{mm}$