

Features :

- Low $V_{CE(sat)}$ trench IGBT technology
- 10 μ s short circuit capability
- $V_{CE(sat)}$ with positive temperature coefficient
- Maximum junction temperature 175°C

Typical Applications :

- Inverter for motor drive
- AC and DC servo drive amplifier
- Uninterruptible power supply

SYMBOL	CHARACTERISTIC	TEST CONDITIONS	VALUE			UNIT
			Min	Type	Max	
V_{CES}	Collector-Emitter voltage	$T_j=25^\circ\text{C}$			1700	V
V_{GES}	Gate-Emitter voltage	$T_j=25^\circ\text{C}$			± 20	V
I_C	Collector current	Continuous@ $T_C=100^\circ\text{C}$			300	A
I_{CP}		$T_P=1\text{ms}$			600	A
P_D	Maximum Power Dissipation	$T_j=175^\circ\text{C}$, 1 device			1829	W
T_j	Junction temperature	/			175	$^\circ\text{C}$
T_{stg}	Storage temperature	/	-40		125	$^\circ\text{C}$
V_{iso}	Isolation between terminal and copper base	$T_j=25^\circ\text{C}$, AC: 1minute	4000			V
Screw torque	Mounting(M6)	/	3.5		5.0	N·m
	Terminals(M6)	/	3.5		5.0	N·m
I_{CES}	Zero gate voltage collector current	$T_j=25^\circ\text{C}$, $V_{CE}=1700\text{V}$, $V_{GE}=0\text{V}$			1.0	mA
I_{GES}	Gate-Emitter leakage current	$T_j=25^\circ\text{C}$, $V_{CE}=0\text{V}$, $V_{GE}=\pm 20\text{V}$			± 0.4	μA
$V_{GE(th)}$	Gate-Emitter threshold voltage	$T_j=25^\circ\text{C}$, $V_{CE}=20\text{V}$, $I_C=12\text{mA}$	5.6	6.2	6.8	V
$V_{CE(sat)}$	Collector-Emitter saturation voltage	$T_j=25^\circ\text{C}$, $V_{GE}=15\text{V}$, $I_C=300\text{A}$		1.85	2.20	V
		$T_j=125^\circ\text{C}$, $V_{GE}=15\text{V}$, $I_C=300\text{A}$		2.25		V
		$T_j=150^\circ\text{C}$, $V_{GE}=15\text{V}$, $I_C=300\text{A}$		2.35		V
R_{Gint}	Internal gate resistor	$T_j=25^\circ\text{C}$		2.5		Ω
C_{ies}	Input capacitance	$T_j=25^\circ\text{C}$, $V_{CE}=25\text{V}$, $V_{GE}=0\text{V}$, $f=1\text{MHz}$		36.1		nF
C_{res}	Reverse transfer capacitance			0.88		nF
t_{on}	Turn-on time	$T_j=125^\circ\text{C}$, $V_{CC}=900\text{V}$, $I_C=300\text{A}$, $V_{GE}=\pm 15\text{V}$, $R_g=2.4\Omega$, Inductive load		224		ns
t_r				55		ns
t_{off}	Turn-off time			611		ns
t_f				159		ns
E_{on}	Turn-on energy loss per pulse			96.8		mJ
E_{off}	Turn-off energy loss per pulse			99.0		mJ
I_{SC}	SC data		$t_{SC} \leq 10 \mu\text{s}$, $V_{GE}=15\text{V}$, $T_j=150^\circ\text{C}$, $V_{CC}=1000\text{V}$, $V_{CEM} \leq 1700\text{V}$		1200	

V _F	Forward on voltage	T _J =25°C, I _F =300A, V _{GE} =0V	1.80	2.25	V
		T _J =125°C, I _F =300A, V _{GE} =0V	1.90		V
		T _J =150°C, I _F =300A, V _{GE} =0V	1.95		V
I _{RM}	Peak reverse recovery current	I _F =300A, -diF/dt=5400A/μs, V _R =900V, V _{GE} =-15V, T _J =125°C	357		A
Q _r	Recovered charge		116		μC
E _{rec}	Reverse recovery energy		68.2		mJ
R _{th(j-c)}	Thermal resistance(1 device)	IGBT		0.082	°C/W
		FWD		0.129	°C/W
R _{th(c-f)}	Contact thermal resistance (1 device)	With thermal compound	0.033		°C/W
W _t	Weight			300	g
Outline	M42				

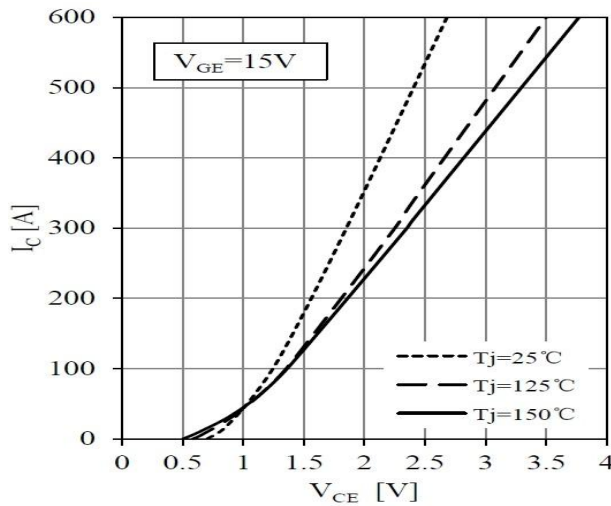

Fig 1. IGBT Typical Output Characteristics

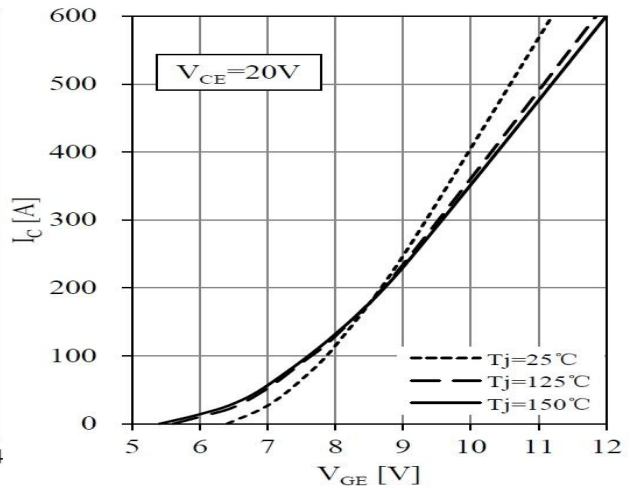

Fig 2. IGBT Typical Transfer Characteristics

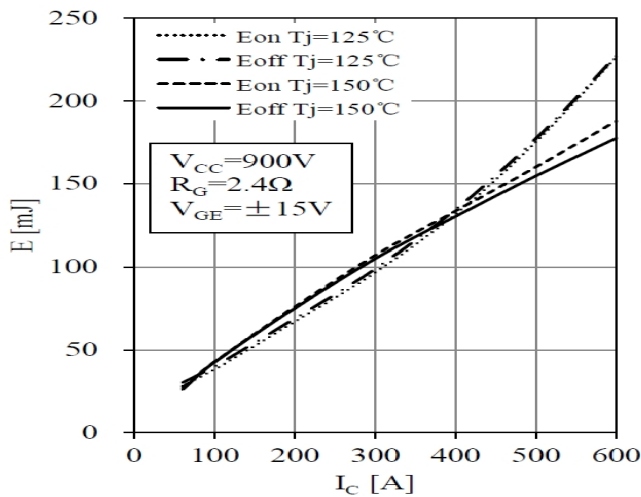

Fig 3. IGBT Switching Loss vs. I_c

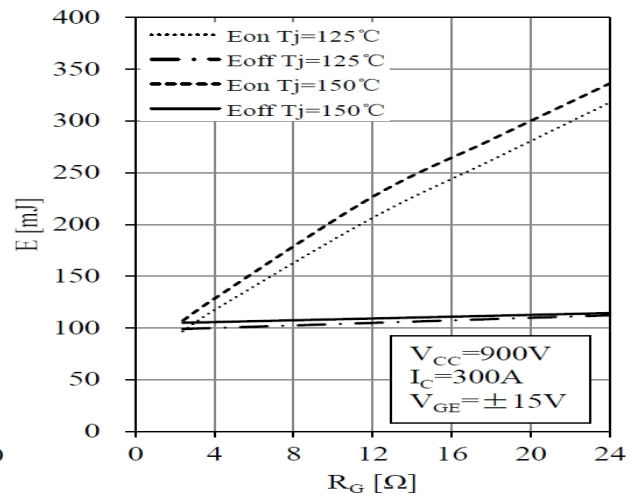

Fig 4. IGBT Switching Loss vs. R_G

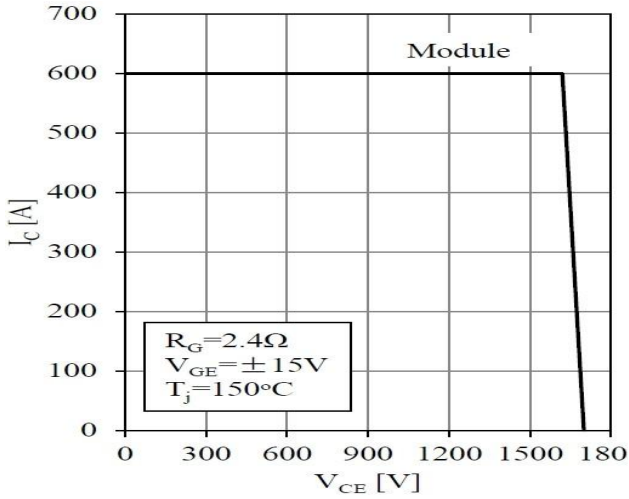

Fig 5. RBSOA

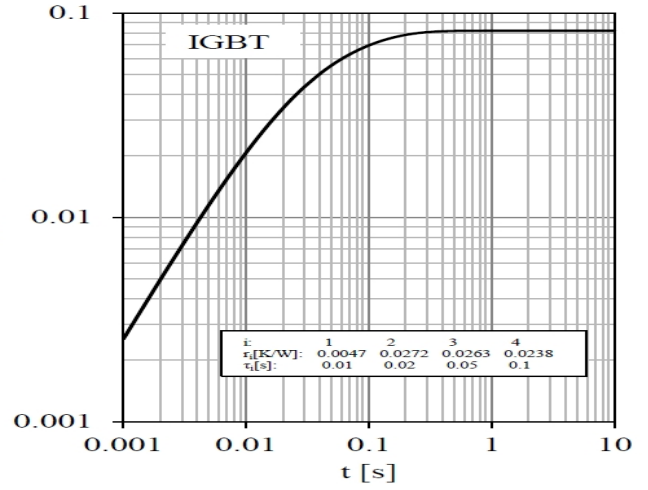

Fig 6. IGBT Transient Thermal Impedance

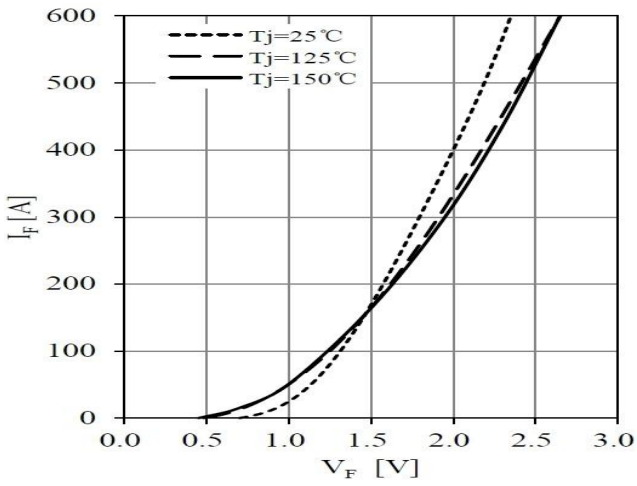

Fig 7. Forward Characteristics of Diode

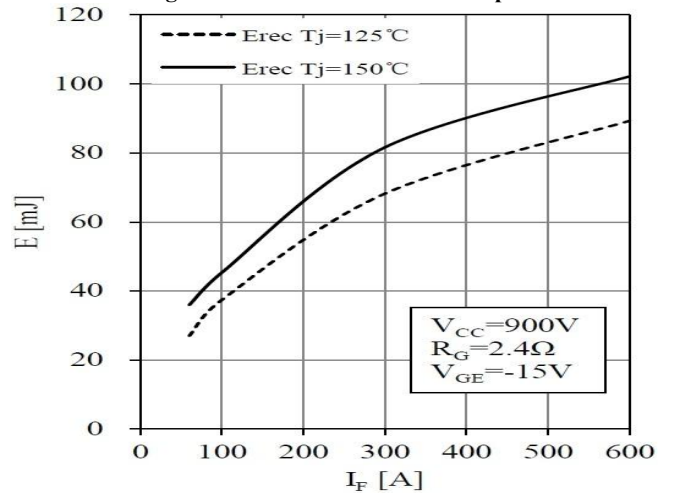

Fig 8. Diode Switching Loss vs. I_F

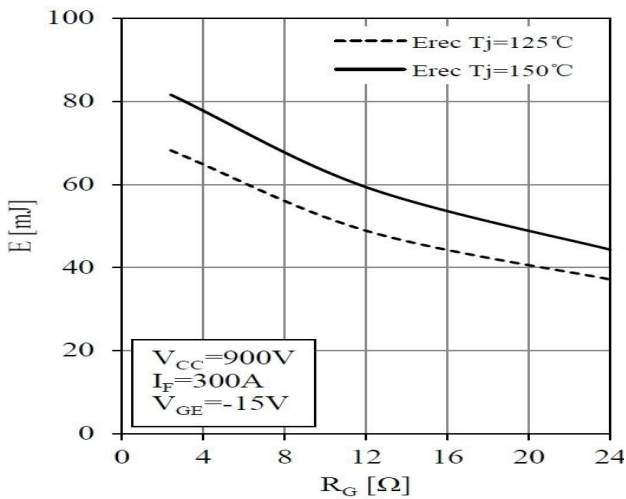

Fig9. Diode Switching Loss vs. R_G

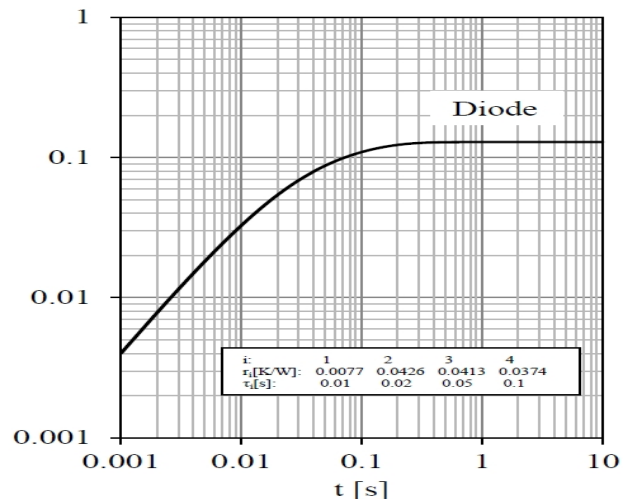
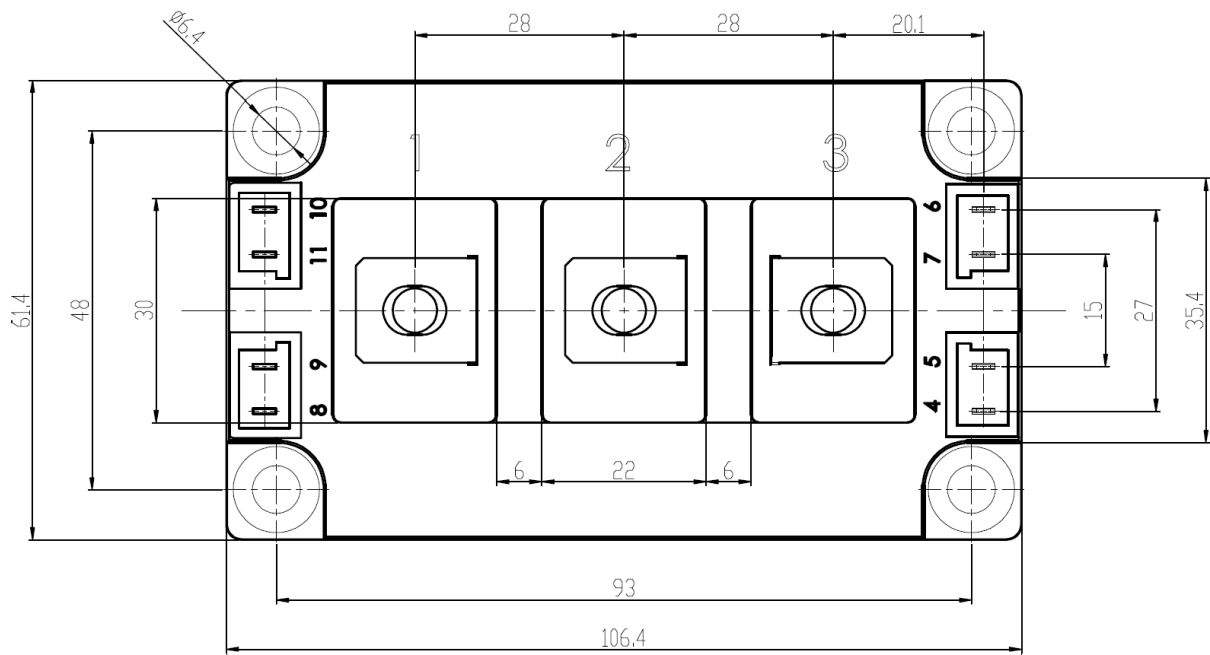
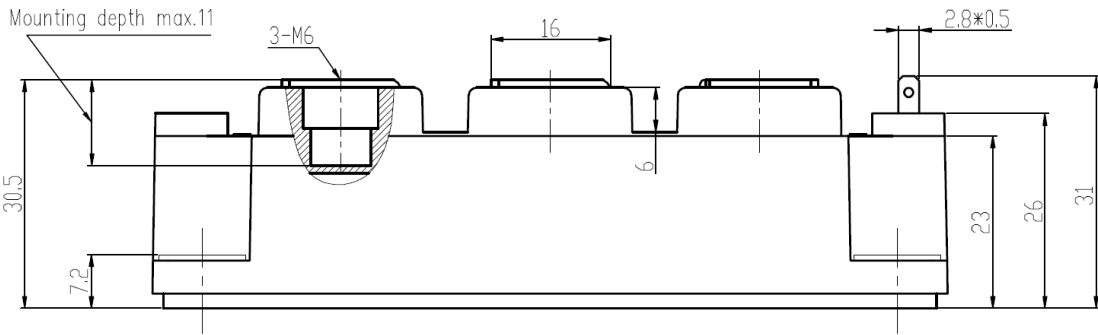

Fig 10. Diode Transient Thermal Impedance

Outline & Circuit Diagram



Unmarked dimensional tolerance : $\pm 0.5\text{mm}$

