

**Features:**

- High speed switching
- Voltage drive
- Low inductance module structure

**Typical Applications:**

- Inverter for Motor Drive
- Inverter welding machines
- Uninterruptible Power Supply
- Industrial machines

SYMBOL	CHARACTERISTIC	TEST CONDITIONS	VALUE			UNIT
			Min.	Typ.	Max.	
$V_{GES}$	Gate-Emitter voltage	$T_j=25^{\circ}\text{C}$			$\pm 30$	V
$I_C$	Collector current	Continuous@ $T_C=100^{\circ}\text{C}$			150	A
$I_{CP}$		$t_p=1\text{ms}$			300	A
$P_C$	Collector power dissipation	$T_C=25^{\circ}\text{C}$ , 1 device			714	W
$T_j$	Junction temperature	/			175	$^{\circ}\text{C}$
$T_{vj(op)}$	Temperature under switching conditions	$T_{vj\ op} > 150^{\circ}\text{C}$ is only allowed for operation at overload conditions.	-40		175	$^{\circ}\text{C}$
$T_{stg}$	Storage temperature	/	-40		125	$^{\circ}\text{C}$
$V_{iso}$	Isolation between terminal and copper base	$T_j=25^{\circ}\text{C}$ , AC: 1minute	2500			V
Screw torque	Mounting(M6)	/	3.5		5.0	N·m
	Terminals(M5)	/	2.4		3.0	N·m
$I_{CES}$	Zero gate voltage collector current	$T_j=25^{\circ}\text{C}$ , $V_{CE}=1200\text{V}$ , $V_{GE}=0\text{V}$			1.0	mA
$I_{GES}$	Gate-Emitter leakage current	$T_j=25^{\circ}\text{C}$ , $V_{CE}=0\text{V}$ , $V_{GE}=\pm 20\text{V}$			$\pm 2$	$\mu\text{A}$
$V_{GE(th)}$	Gate-Emitter threshold voltage	$T_j=25^{\circ}\text{C}$ , $V_{CE}=20\text{V}$ , $I_C=150\text{mA}$	4.5		8.5	V
$V_{CE(sat)}$	Collector-Emitter saturation voltage	$T_j=25^{\circ}\text{C}$ , $V_{GE}=15\text{V}$ , $I_C=150\text{A}$		1.80	2.20	V
		$T_j=125^{\circ}\text{C}$ , $V_{GE}=15\text{V}$ , $I_C=150\text{A}$		1.95		V
		$T_j=150^{\circ}\text{C}$ , $V_{GE}=15\text{V}$ , $I_C=150\text{A}$		2.25		V
$C_{ies}$	Input capacitance	$T_j=25^{\circ}\text{C}$ , $V_{CE}=10\text{V}$ , $V_{GE}=0\text{V}$ , $f=1\text{MHz}$		12.6		nF
$t_{on}$	Turn-on time	$T_j=150^{\circ}\text{C}$ , $V_{CC}=600\text{V}$ , $I_C=150\text{A}$ , $V_{GE}=\pm 15\text{V}$ , $R_G=5.1\Omega$ , Inductive load		160		ns
$t_r$				50		ns
$t_{off}$	Turn-off time	$T_j=150^{\circ}\text{C}$ , $V_{CC}=600\text{V}$ , $I_C=150\text{A}$ , $V_{GE}=\pm 15\text{V}$ , $R_G=5.1\Omega$ , Inductive load		680		ns
$t_f$				250		ns
tsc	Short circuit withstand time	$T_j=150^{\circ}\text{C}$ , $V_{CC}=720\text{V}$ , $V_{GE}=\pm 15\text{V}$ , $R_G=5.1\Omega$	10			$\mu\text{s}$
$V_F$	Forward on voltage	$T_j=25^{\circ}\text{C}$ , $I_F=150\text{A}$		2.10	2.60	V
		$T_j=125^{\circ}\text{C}$ , $I_F=150\text{A}$		2.00		V
		$T_j=150^{\circ}\text{C}$ , $I_F=150\text{A}$		1.90		V
$t_{rr}$	Reverse recovery time	$T_j=125^{\circ}\text{C}$ , $I_F=150\text{A}$		150		ns
		$T_j=150^{\circ}\text{C}$ , $I_F=150\text{A}$		160		ns
$R_{th(j-c)}$	Thermal resistance(1 device)	IGBT			0.21	$^{\circ}\text{C/W}$
		FWD			0.31	$^{\circ}\text{C/W}$
$R_{th(c-f)}$	Contact thermal resistance (1 device)	With thermal compound		0.050		$^{\circ}\text{C/W}$
$W_t$	Weight				155	g
Outline	M38					

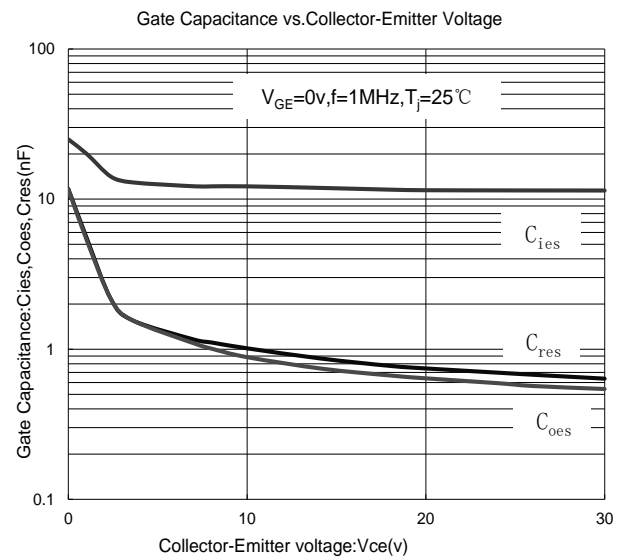
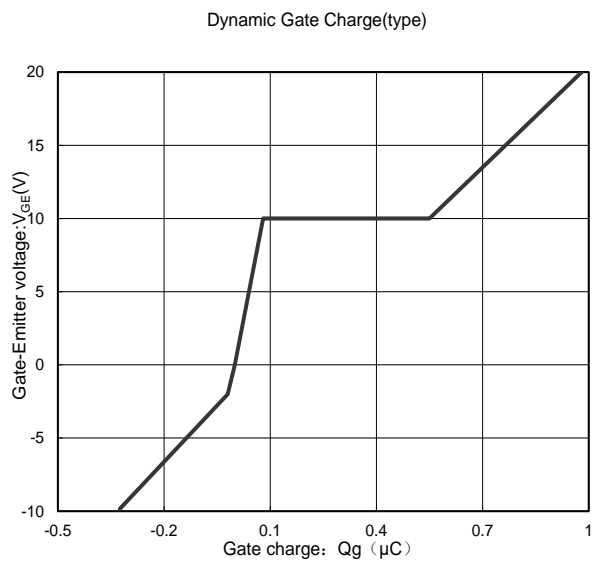
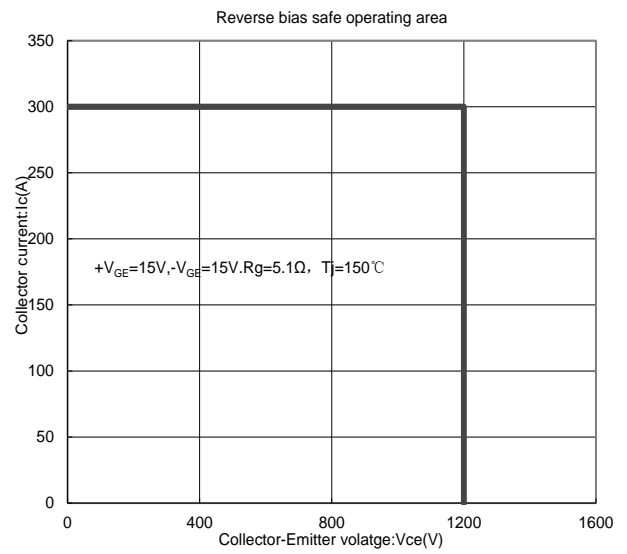
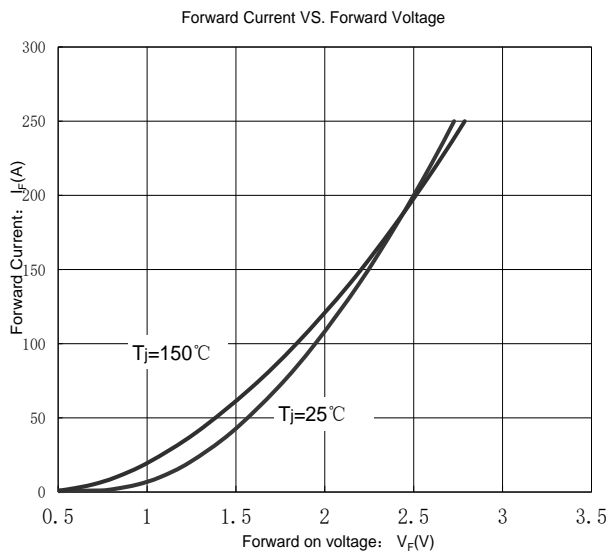
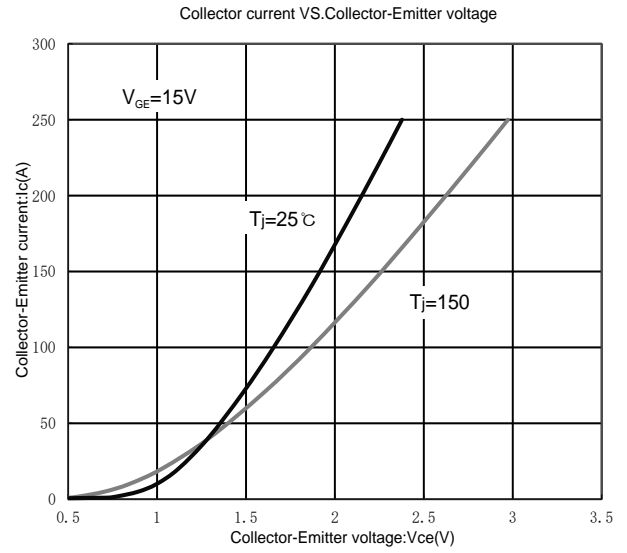
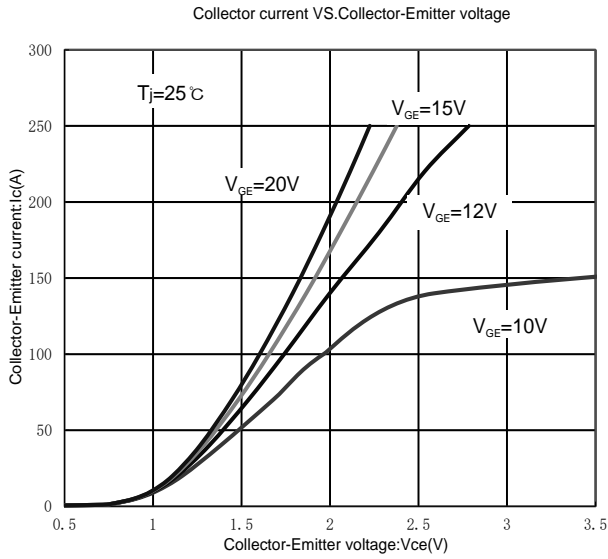

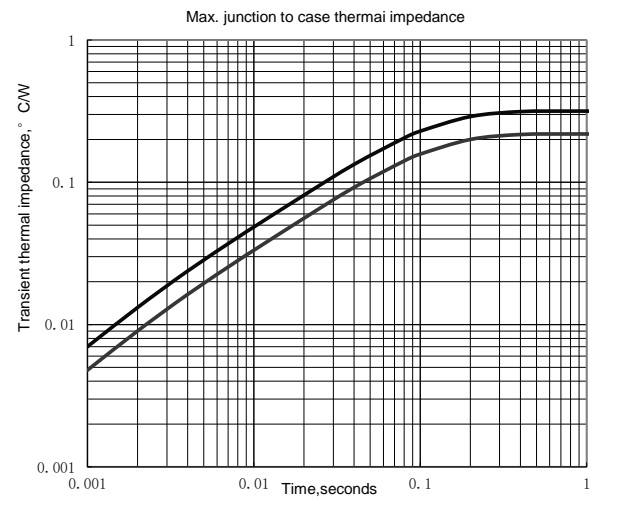
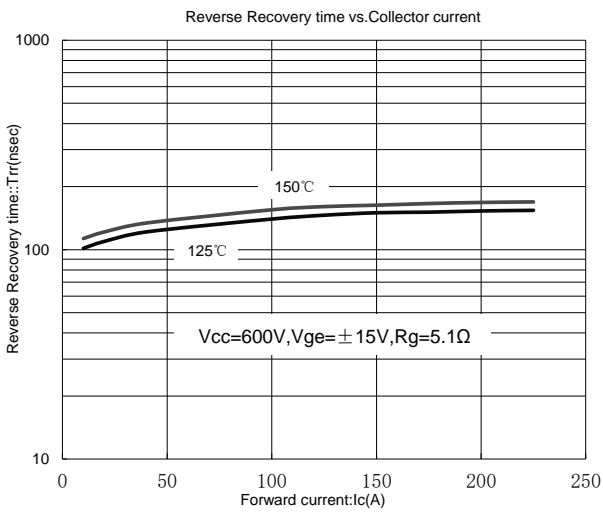
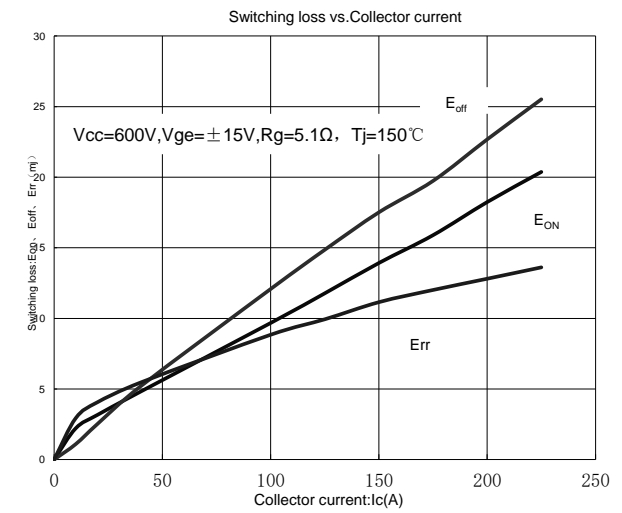
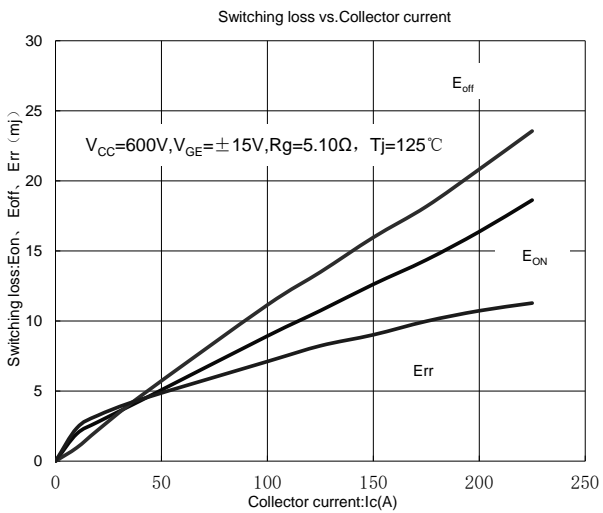
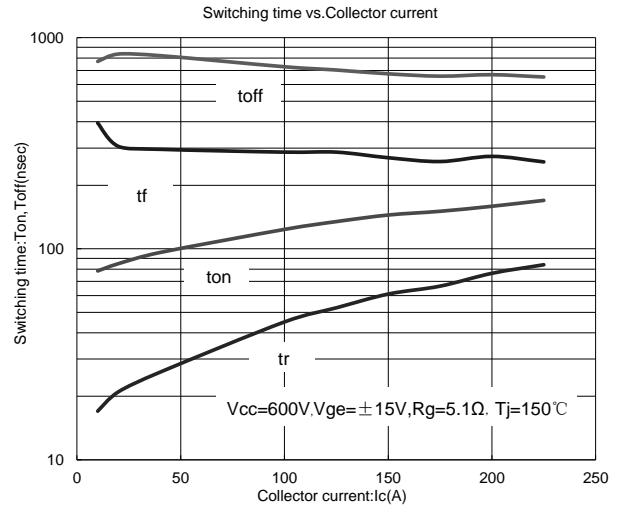
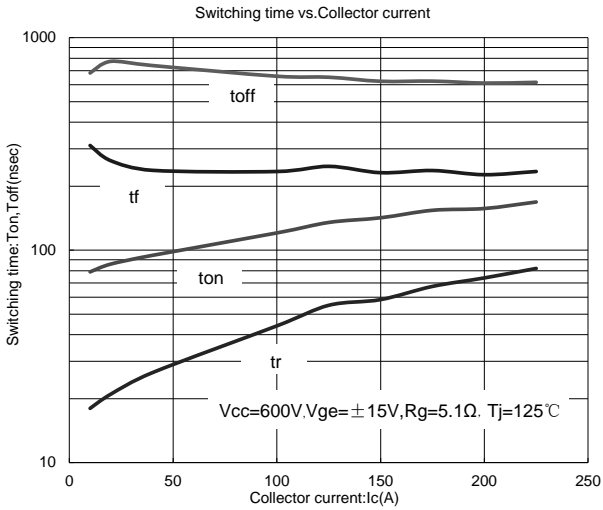

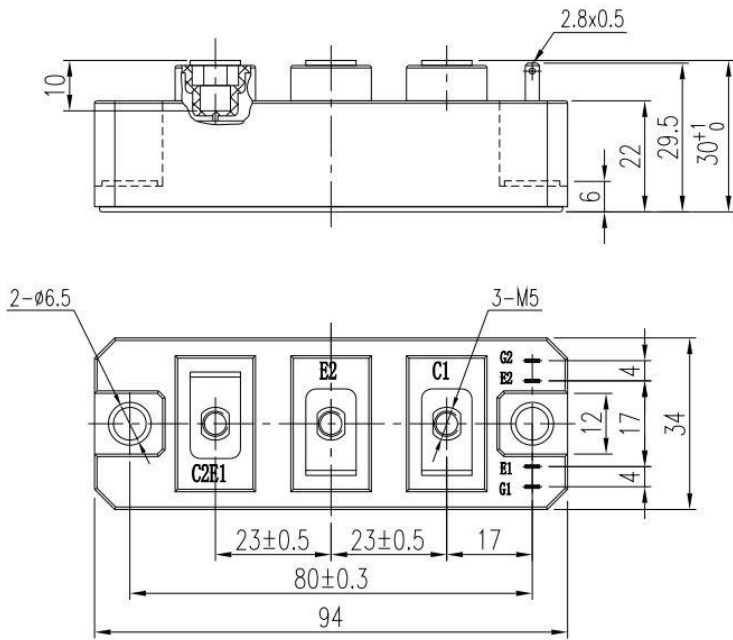

MD150MB120S

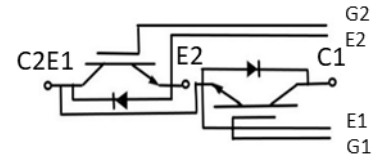

Unmarked dimensional tolerance:  $\pm 0.5\text{mm}$