

Features :

- Isolated mounting base 2500V~
- Pressure contact technology with Increased power cycling capability
- Space and weight saving

Typical Applications

- Inverter
- Inductive heating
- Chopper

V_{DSM}, V_{RSM}	V_{DRM}, V_{RRM}	Type
900V	800V	Mx75THF80
1100V	1000V	Mx75THF100
1300V	1200V	Mx75THF120
1500V	1400V	Mx75THF140
1700V	1600V	Mx75THF160
1900V	1800V	Mx75THF180

SYMBOL	CHARACTERISTIC	TEST CONDITIONS	$T_j(^{\circ}C)$	VALUE			UNIT
				Min	Type	Max	
$I_{T(AV)}$	Mean on-state current	180° half sine wave 50Hz Single side cooled, $T_c=85^{\circ}C$	125			75	A
$I_{T(RMS)}$	RMS on-state current					118	A
I_{DRM} I_{RRM}	Repetitive peak current	at V_{DRM} at V_{RRM}	125			30	mA
I_{TSM}	Surge on-state current	10ms half sine wave $V_R=60\%V_{RRM}$	125			1.60	kA
I^2t	I^2t for fusing coordination					13	$A^2s \cdot 10^3$
V_{TO}	Threshold voltage		125			1.50	V
r_T	On-state slope resistance					4.00	$m\Omega$
V_{TM}	Peak on-state voltage	$I_{TM}=225A$	25			2.60	V
dv/dt	Critical rate of rise of off-state voltage	$V_{DM}=67\%V_{DRM}$	125			800	V/ μs
di/dt	Critical rate of rise of on-state current	Gate source 1.5A $t_r \leq 0.5\mu s$ Repetitive	125			200	A/ μs
tq	Circuit commutated turn-off time	$I_{TM}=200A, t_p=2000\mu s, V_R=50V$ $dv/dt=30V/\mu s, di/dt=-20A/\mu s$	125	20		40	μs
t_{rr}	Reverse recovery time	$I_{TM}=200A, t_p=2000\mu s,$ $-di/dt=20A/\mu s, V_R=50V$	125		2		μs
I_{GT}	Gate trigger current	$V_A=12V, I_A=1A$	25	30		150	mA
V_{GT}	Gate trigger voltage			1.0		2.5	V
I_H	Holding current			20		200	mA
V_{GD}	Non-trigger gate voltage	$V_{DM}=67\%V_{DRM}$	125	0.2			V
$R_{th(j-c)}$	Thermal resistance Junction to case	Single side cooled per chip				0.200	$^{\circ}C/W$
$R_{th(c-h)}$	Thermal resistance case to heatsink	Single side cooled per chip				0.040	$^{\circ}C/W$
V_{iso}	Isolation voltage	50Hz, R.M.S, $t=1min, I_{iso}=1mA(MAX)$		2500			V
F_m	Terminal connection torque(M6)				6.0		N·m
	Mounting torque(M6)				6.0		N·m
T_{vj}	Junction temperature			-40		125	$^{\circ}C$
T_{stg}	Stored temperature			-40		125	$^{\circ}C$
W_t	Weight				320		g
Outline	M02						

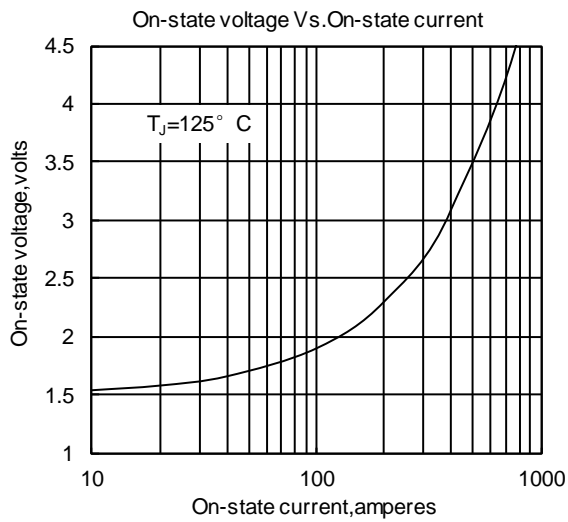

Fig.1

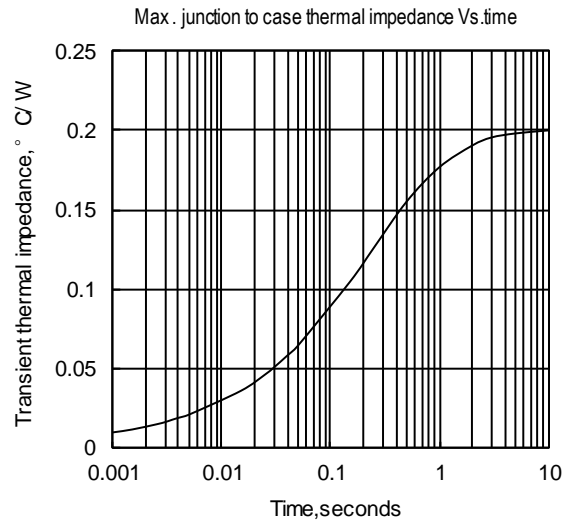

Fig.2

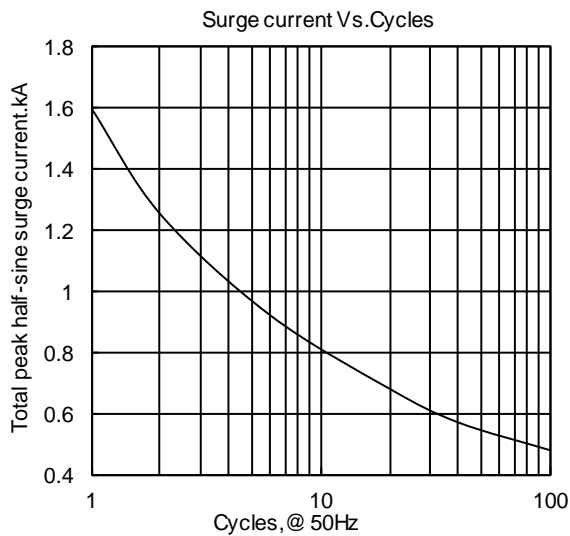

Fig.3

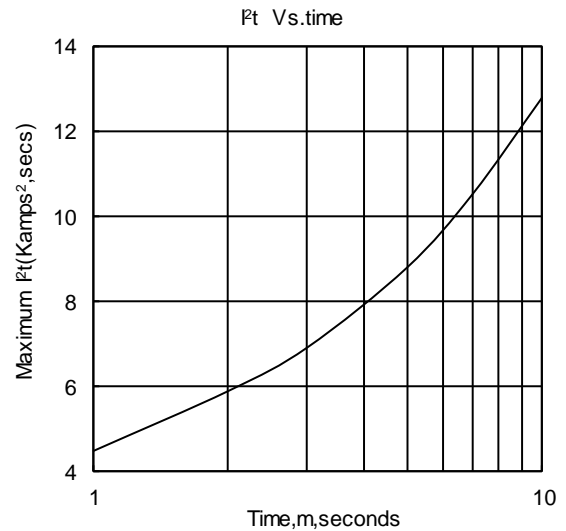

Fig.4

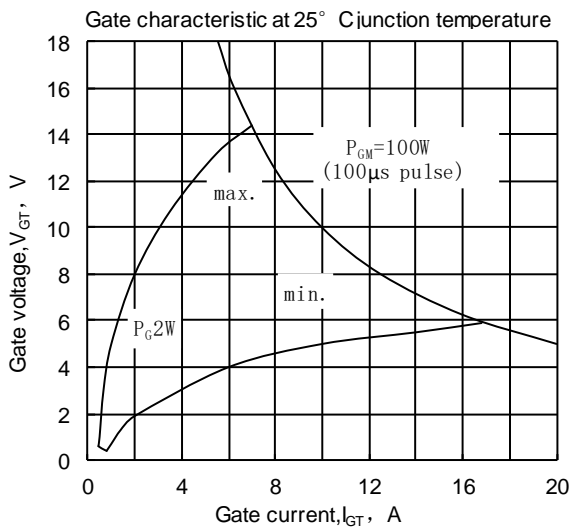

Fig.5

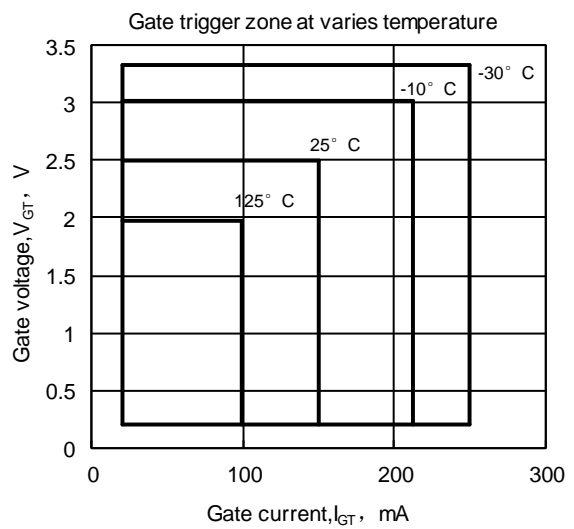
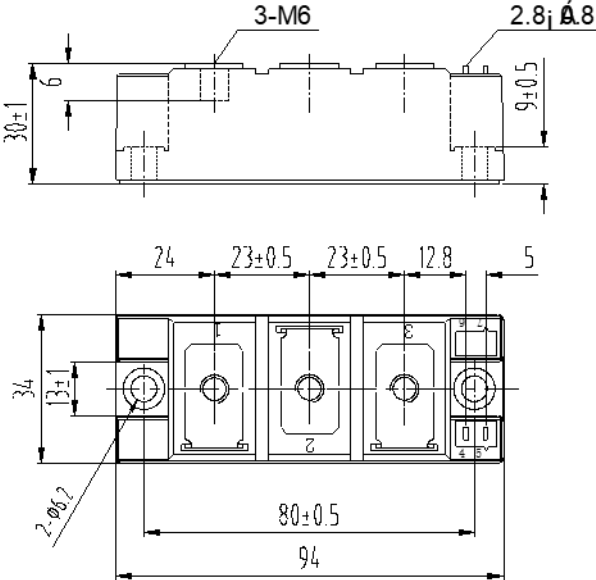

Fig.6

Outline:



MD75THF



MR75THF

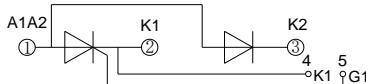

MC75THF

